

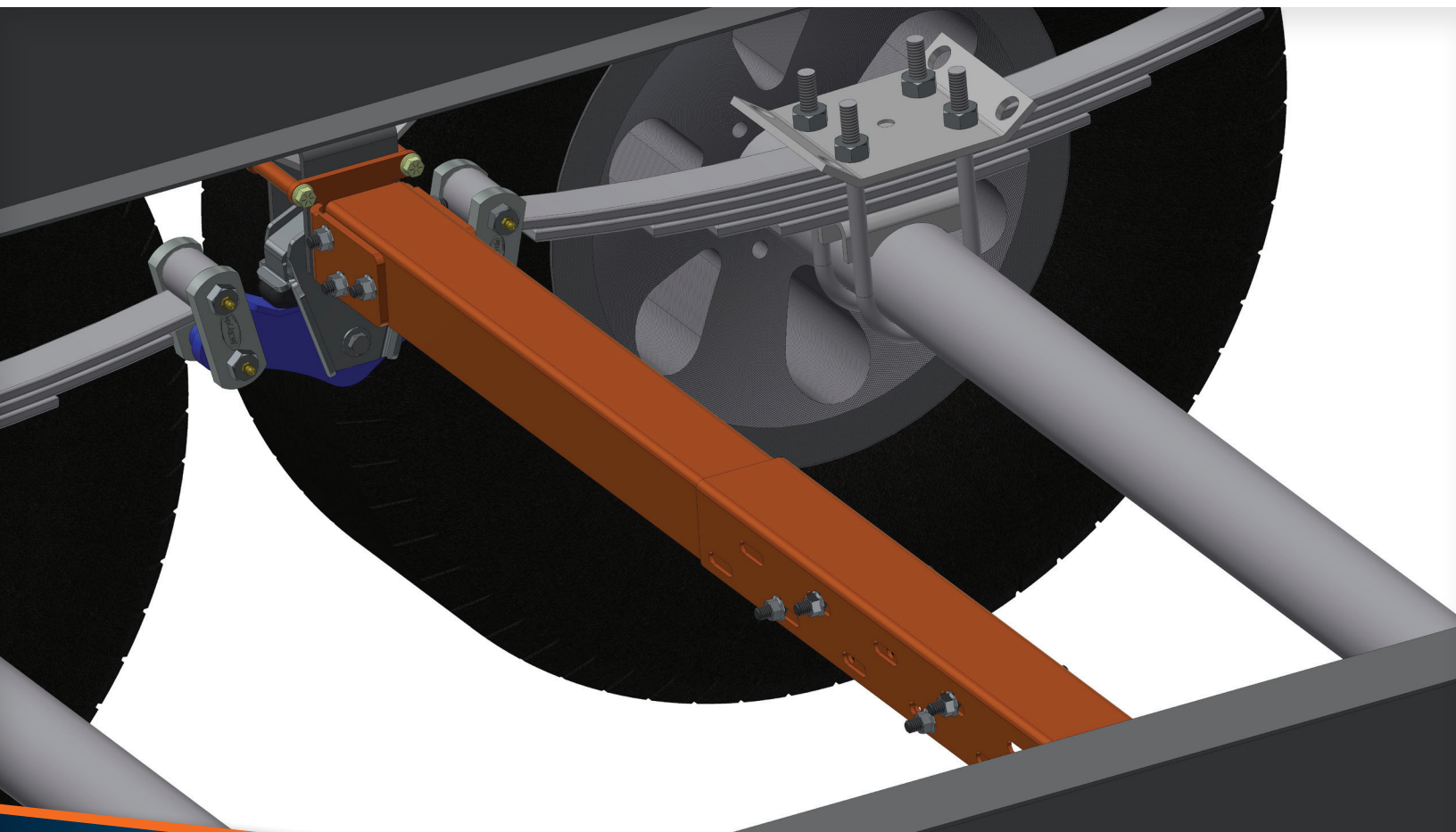

X-FACTOR CROSSMEMBER

INSTALLATION INSTRUCTIONS



Above. Beyond. Always.

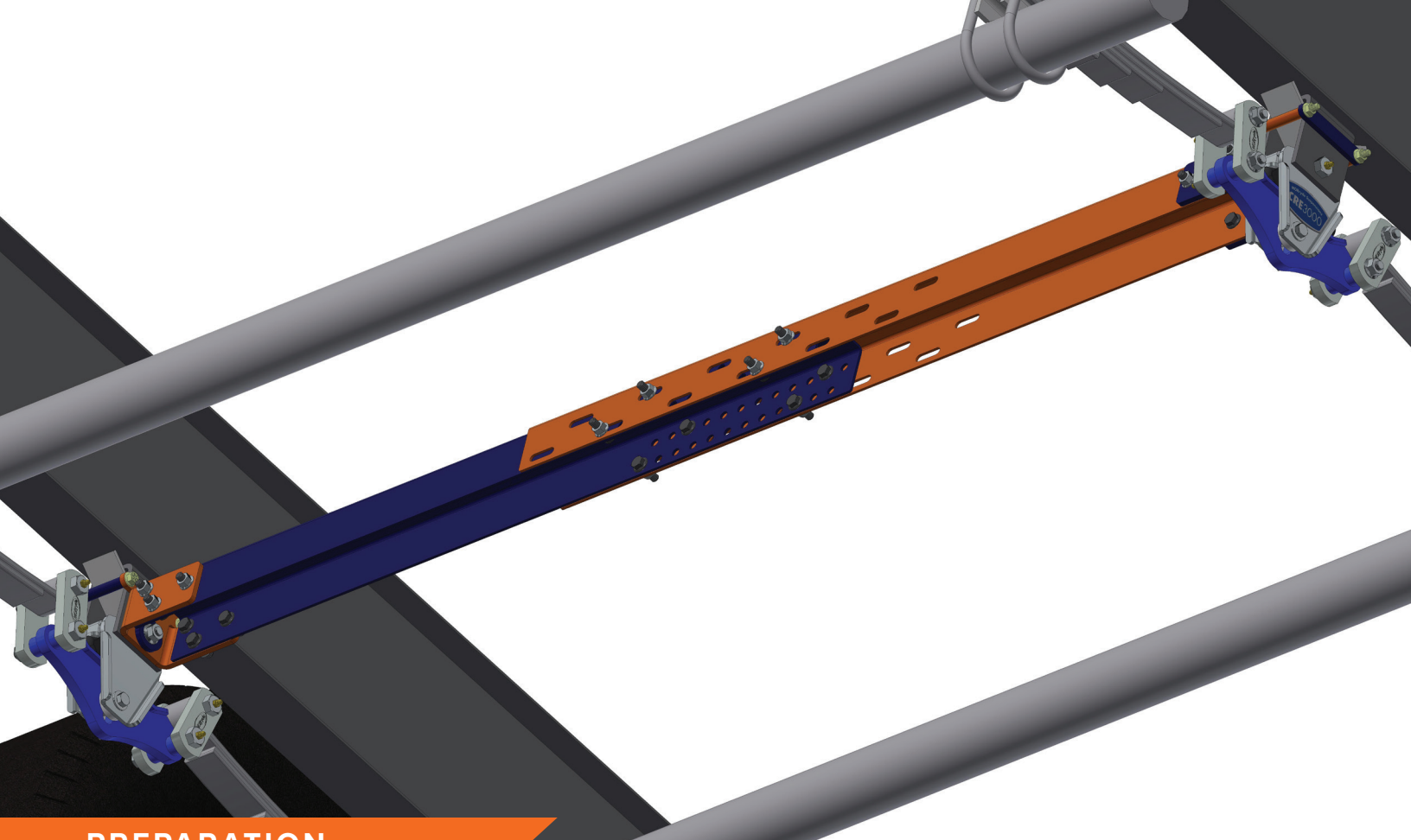

PREPARATION

General Safety & Warnings:

- ⚠ WARNING** Read and understand all instructions and warnings prior to installation of the crossmember and towing the trailer.
- ⚠ WARNING** Failure to follow the instructions and heed the warnings of this document may result in death or serious injury, damage to the trailer and/or property, and/or voidance of the product warranty. Always utilize appropriate safety equipment, i.e. proper eye protection, hearing protection, gloves, etc.
- ⚠ WARNING** You are personally responsible for following safe installation procedures, completing appropriate safety checks, and safely towing the trailer.
- ⚠ WARNING** Exercise caution and common sense when lifting and supporting the trailer. Use only appropriately rated support devices that are fit for use. Follow safe trailer supporting procedures recommended by the trailer and support device manufacturers.



Above. Beyond. Always.

STANDARD X-FACTOR CROSSMEMBER

XF12-001 INSTALLATION INSTRUCTIONS

The MORryde X-Factor Crossmember kit is designed to provide added strength and reinforcement to trailer frames. The crossmember can be installed onto a single spring hanger, or for added strength and reinforcement, onto all the spring hangers on the frame. The installation instructions for the kit are detailed below.

Please note: There are specific installation instructions for trailers equipped with a MORryde LRE suspension system. Contact MORryde Parts at 574.293.1581 or email parts@morryde.com.

XF12-001 PARTS LISTING

Item	Qty	Part Number	Description
1	2	006-092-01	7/16-20 Flange Locknut GR8 Zinc*
2	2	UO115-889	9/16-7/16-20 x 3.4 Wet Bolt GR5 Zinc**
3	20	UO116-399	3/8-16 Flange Locknut GR8 Zinc
4	20	UO115-400	3/8-16 x 1 Flange Bolt GR8 Phos & Oil
5	4	UO115-951	5/16-18 x 3 1/2 Flange Bolt GR8 Zinc
6	4	UO116-189	5/16-18 Flange Locknut GRG Zinc
7	2	XF205-001	Hanger Bracket Plate
8	2	XF205-002	Spacers
9	1	XF209-001	Inner Hanger Bracket Adapter
10	1	XF209-002	Outer Hanger Bracket Adapter
11	1	XF209-005	X-Factor Inner Channel
12	1	XF209-006	X-Factor Outer Channel
13	4	XF214-001	Spacer Tube

Tools Required:

- Torque Wrench
- 11/16" or 3/4" Socket
- 13/16" Wrench
- 9/16" Socket & Wrench
- 1/2" Socket & Wrench
- Floor Jacks*
- Safety Stands*
- Alternate tools for angled frame hanger:
 - 5/16" drill bit & drill

***WARNING** Check for adequate capacity

**1/2-20 Flange Locknut GR8 Zinc*

***9/16-1/2-20 x 3.4 wet bolt GR5 Zinc*

NOTE

The Standard X-Factor Crossmember kit comes with either:

- > Two 9/16 - 7/16-20 x 3.4" Wet Bolts and Flange Locknuts **OR**
- > Two 9/16 - 1/2-20 x 3.4" Wet Bolts and Flange Locknuts

- > The 9/16-7/16-20 x 3.4" requires an 11/16" socket to tighten to 40 ft-lbs **OR**
- > 9/16 1/2-20 x 3.4" requires a 3/4" socket to tighten to 80 ft-lbs

STANDARD X-FACTOR CROSSMEMBER

XF12-001 INSTALLATION INSTRUCTIONS

INSTALLATION

STEP 1

Support the frame with jacks on each frame rail. Support the axles with floor jacks. While not the easiest method, you can lift and work on one side at a time if needed.

NOTE

If you are installing the crossmember at the equalizer, it is not necessary to remove the tires as the center bolt can be easily accessed from between the wheels. However, if you are installing the crossmember at the end hangers with the leaf spring, remove the tires to access the hanger bolts.

STEP 2

Remove the shoulder bolt from the frame hanger and replace it with one 9/16" wet bolt (shoulder bolt with a grease zerk) included in the installation kit. The bolt should point toward the inside of the trailer, and the exit hole for the grease should point to a 3 or 9 o'clock position. Use a hammer to tap the wet bolt into the frame hanger. Use a small diameter socket to fit over the grease zerk and tap the bolt in place or remove the zerk, tap the bolt in place, and reinstall the zerk. Do not install the nut until the next step (it is important not to damage the grease zerk).

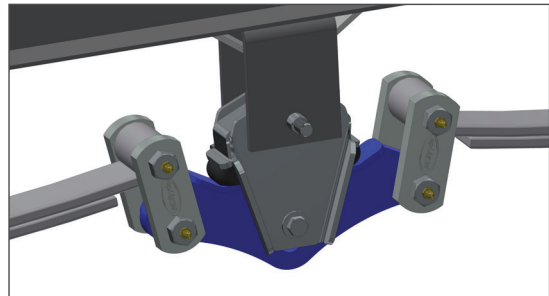

Above. Beyond. Always.

STEP 3

Install the Outer Hanger Bracket Adapter on the trailer frame hanger. Slide one Spacer over the end of the 9/16" wet bolt and thread the 7/16" or 1/2" flange nut on by hand. Do not tighten the nut yet.

Insert two 5/16" flange bolts through the ears of the Outer Hanger Bracket Adapter. Slide a Spacer Tube over each the bolt. Next, slide one Hanger Bracket Plate over the ends of the bolts on the outside of the frame hanger and install the 5/16" flange nuts. Do not tighten yet.

Torque the 7/16" flange nut on the 9/16" wet bolt to 40 ft-lbs (or the 1/2" nut to 80 ft-lbs) with an 11/16" (or 3/4") socket while using a 13/16" wrench to hold the bolt in position. Torque the 5/16" flange nuts evenly on each side of the hanger to 20 ft-lbs with a 1/2" socket and wrench.

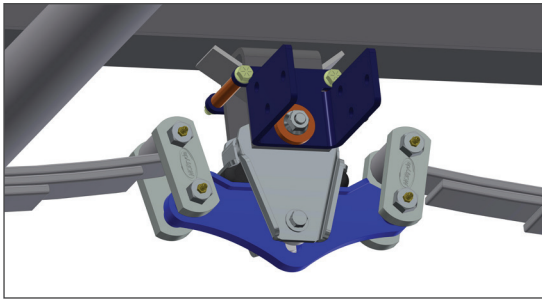

STEP 4

Install the X-Factor Outer Channel onto the Outer Hanger Bracket Adapter using (6) 3/8" flange bolts and 3/8" flange nuts. Hand tighten, but do not torque yet.

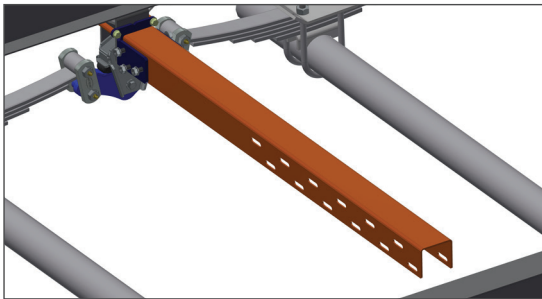

STEP 5

Repeat Steps 2 - 4 for the opposite side with the Inner Hanger Bracket Adapter, X-Factor Inner Channel, and (2) Spacer Tubes.

STEP 6

Line up the holes on both crossmember channels, and insert (4) 3/8" flange bolts on each side, utilizing the holes farthest from the center in both the top and bottom rows. Install the 3/8" flange nuts.

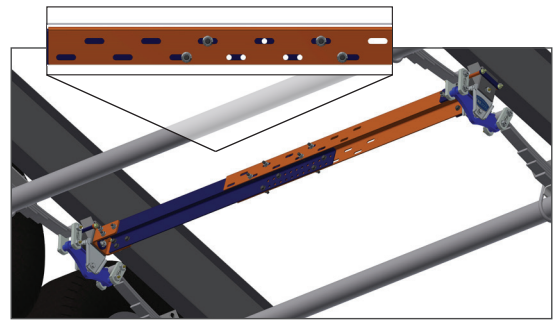

STEP 7

Torque all 3/8" hardware from the previous steps to 40 ft-lbs with a 9/16" socket and wrench.

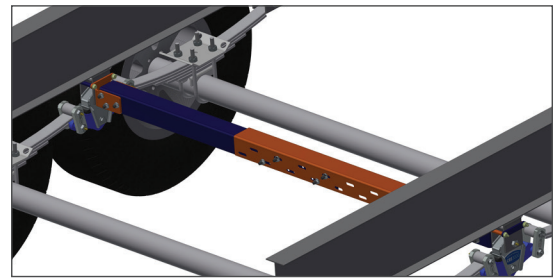

STEP 8

Reinstall tires, if necessary, and torque lug nuts to recommended specifications. Remove the jacks and supports from the frame and axle.

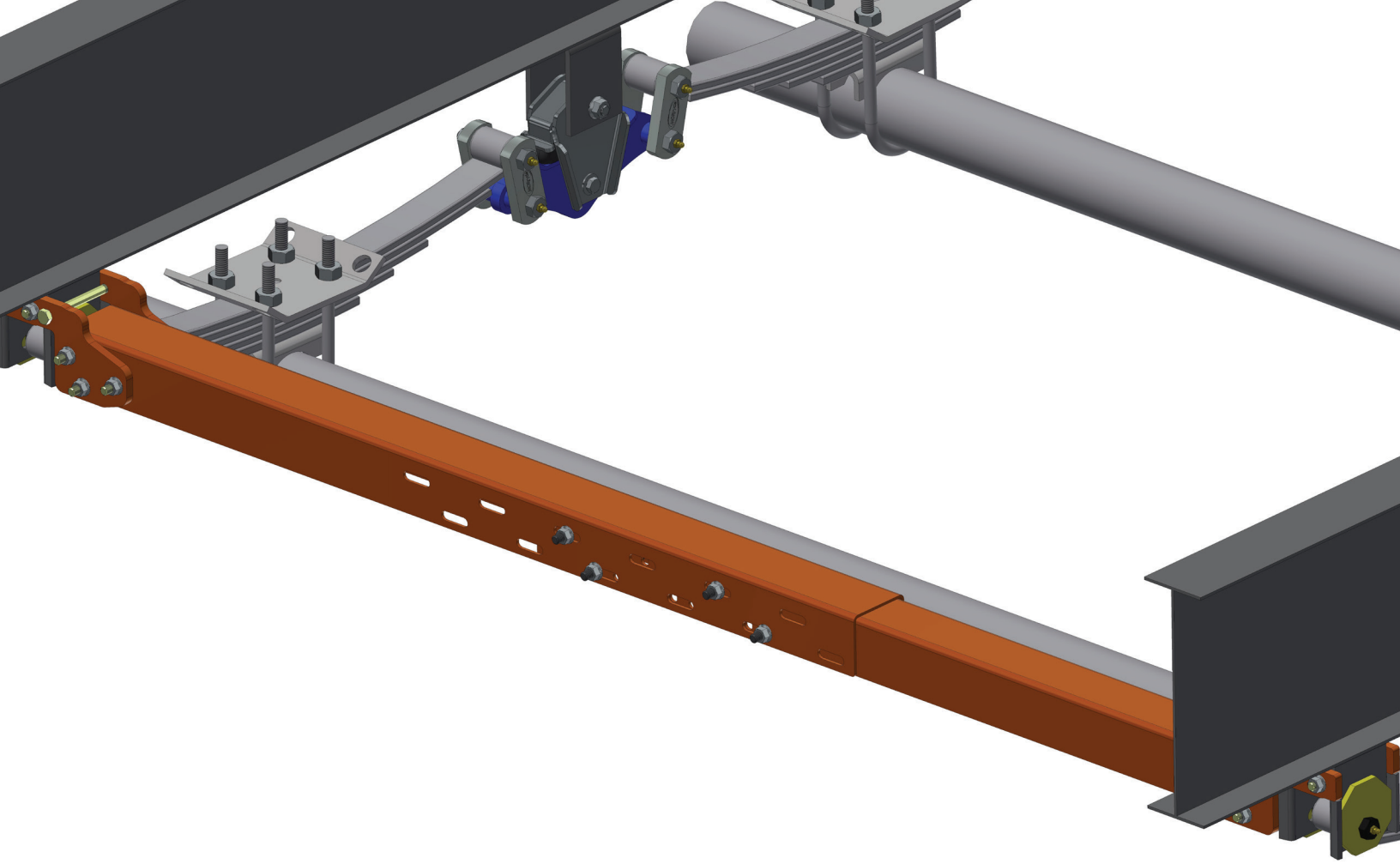

CORRECT TRACK

X-FACTOR CROSSMEMBER



Above. Beyond. Always.

CORRECT TRACK X-FACTOR CROSSMEMBER

XF12-001 + XF12-002 INSTALLATION INSTRUCTIONS

XF12-002 PARTS LISTING

Item	Qty	Part Number	Description
1	6	UO116-399	3/8-16 Flange Locknut GR8 Zinc
2	12	UO115-003	3/8-16 x 1-1/4 Hex Head Bolt GR8 Zinc
3	6	UO115-639	3/8-16 x 4-1/4 Hex Head Bolt GR8 Zinc
4	4	XF205-003	Correct Track Adapter
5	2	XF205-004	Spacer Plate

> Refer to Page 2 for XF12-001 Parts Listing

Tools Required:

- Torque Wrench
- 9/16" Socket & Wrench
- Floor Jacks*
- Safety Stands*

***WARNING** Check for adequate capacity

PREPARATION

General Safety & Warnings:

⚠ WARNING Read and understand all instructions and warnings prior to installation of the crossmember and towing the trailer.

⚠ WARNING Failure to follow the instructions and heed the warnings of this document may result in death or serious injury, damage to the trailer and/or property, and/or voidance of the product warranty. Always utilize appropriate safety equipment, i.e. proper eye protection, hearing protection, gloves, etc.

⚠ WARNING You are personally responsible for following safe installation procedures, completing appropriate safety checks, and safely towing the trailer.

⚠ WARNING Exercise caution and common sense when lifting and supporting the trailer. Use only appropriately rated support devices that are fit for use. Follow safe trailer supporting procedures recommended by the trailer and support device manufacturers.

CORRECT TRACK X-FACTOR CROSSMEMBER

XF12-001 + XF12-002 INSTALLATION INSTRUCTIONS

INSTALLATION

NOTE

Because the shoulder bolt will not be removed, this installation can be completed without lifting the trailer. However, lifting the trailer will make it easier to maneuver underneath it. If you decide to lift the trailer, support the frame with jacks on each frame rail. You can also lift and work on one side at a time, if needed.

Only the X-Factor Inner and Outer Channels, (8) 3/8" flange nuts and (8) 3/8-16 x 1 flange bolts from the XF12-001 kit will be used – set everything else aside.

STEP 1

Install (2) Correct Track Adapters on the roadside frame hanger of the trailer using (3) 3/8-16 x 4 1/4 bolts.

Tighten the 3/8" flange nuts more than hand tight, but do not yet torque as you will still need to be able to adjust them.

NOTE

To prevent interference of the flange nuts, the head of the innermost bolt must be installed on the opposite adapter as the outer two bolts.

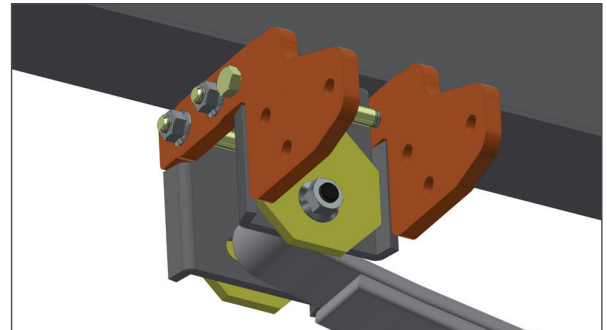

STEP 2

Install the X-Factor Outer Channel onto the (2) Correct Track Adapters on the roadside using (6) 3/8-16 x 1 1/4 bolts and 3/8" flange nuts. Hand tighten, but do not yet torque.

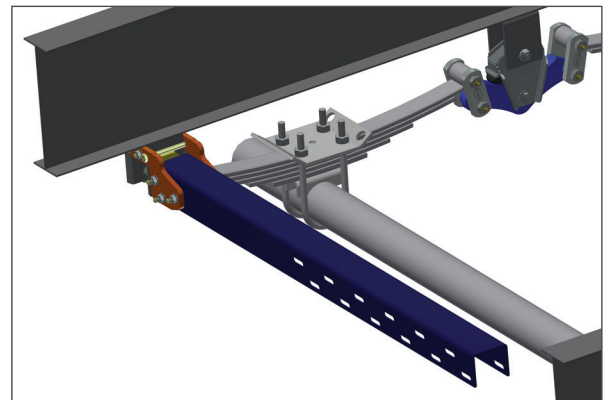

Above. Beyond. Always.

STEP 3

Repeat Steps 1 and 2 for the curbside of the trailer with the remaining (2) Correct Track Adapters, X-Factor Inner Channel, and (3) 3/8-16 x 4 1/2 bolts. Install the (2) Spacer Plates between the Inner Channel and the (2) Correct Track Adapters to obtain the proper distance between the parts.

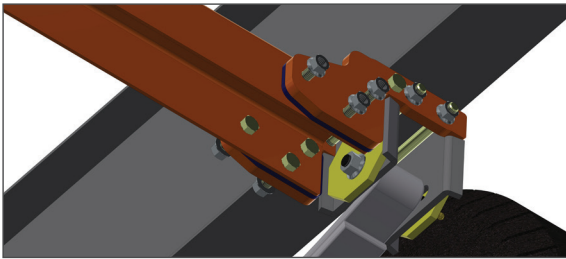

STEP 4

Line up the holes on both crossmember channels, and insert (4) 3/8" flange bolts on each side, utilizing the holes farthest from the center in both the top and bottom rows. Install the 3/8" flange nuts.

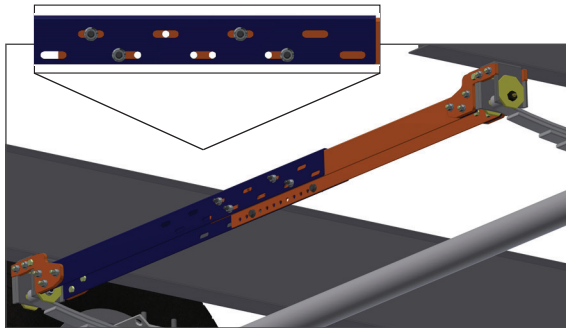

STEP 5

Torque all hardware from the previous steps to 40 ft-lbs using a 9/16" socket and wrench.

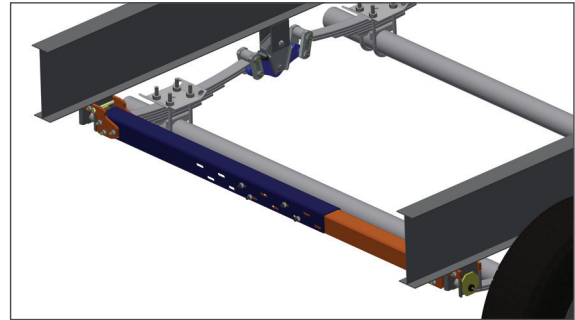

STEP 6

Remove the jacks and supports from the frame and axle.

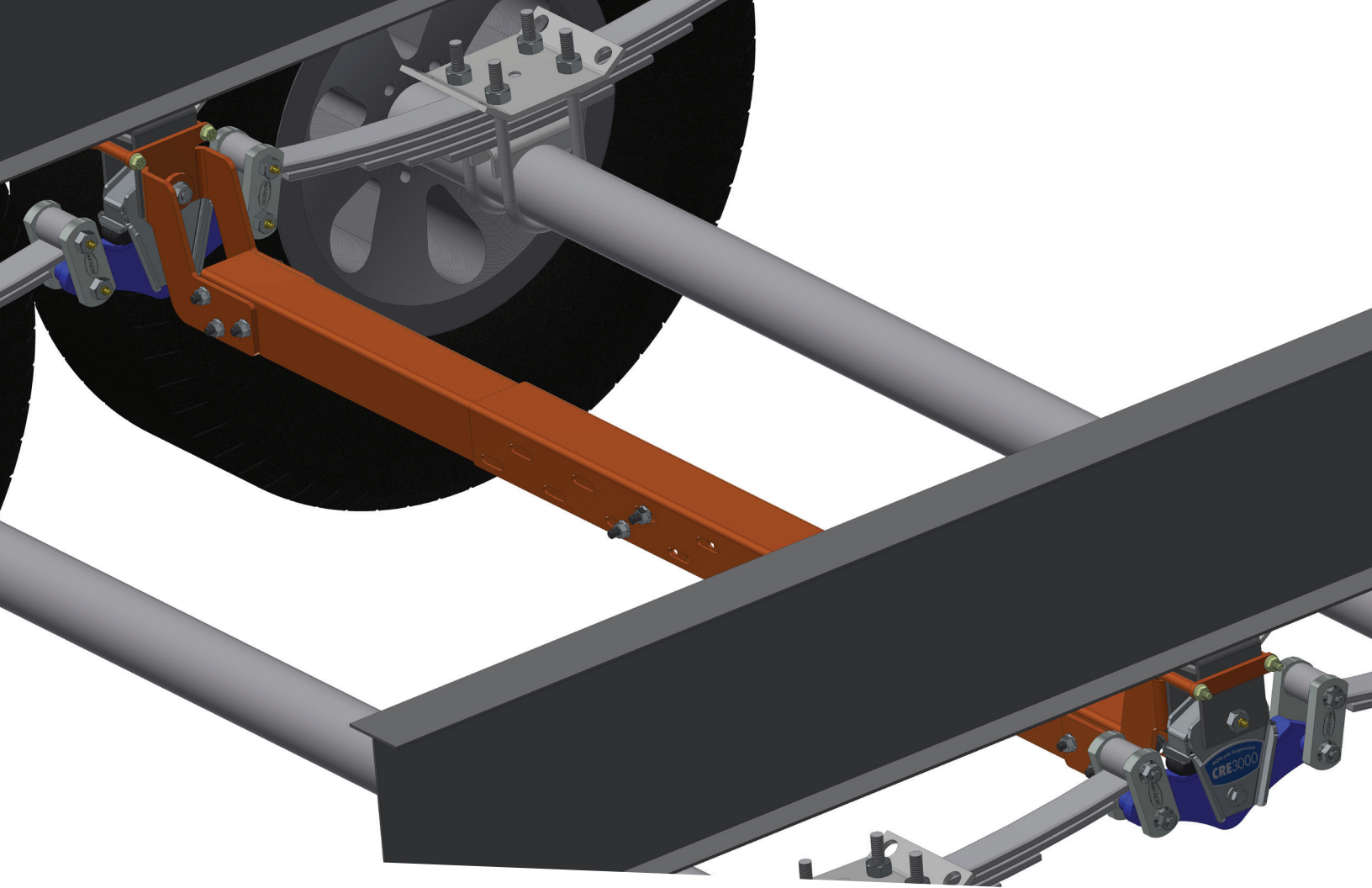

DROP-DOWN

X-FACTOR CROSSMEMBER



Above. Beyond. Always.

DROP-DOWN X-FACTOR CROSSMEMBER

XF12-001 + XF12-003 INSTALLATION INSTRUCTIONS

XF12-003 PARTS LISTING

Item	Qty	Part Number	Description
1	1	XF209-003	Drop Down Outer Hanger Bracket Adapter
2	1	XF209-004	Drop Down Inner Hanger Bracket Adapter

> Refer to Page 2 for XF12-001 Parts Listing

NOTE

The Standard X-Factor Crossmember kit comes with either:

- > Two 9/16 - 7/16-20 x 3.4" Wet Bolts and Flange Locknuts **OR**
- > Two 9/16 - 1/2-20 x 3.4" Wet Bolts and Flange Locknuts

- > The 9/16-7/16-20 x 3.4" requires an 11/16" socket to tighten to 40 ft-lbs **OR**
- > 9/16 1/2-20 x 3.4" requires a 3/4" socket to tighten to 80 ft-lbs

Tools Required:

- Torque Wrench
- 11/16" or 3/4" Socket
- 13/16" Wrench
- 9/16" Socket & Wrench
- 1/2" Socket & Wrench
- Floor Jacks*
- Safety Stands*
- Alternate tools for angled frame hanger:
 - 5/16" drill bit & drill

***WARNING** Check for adequate capacity

PREPARATION

General Safety & Warnings:

⚠ WARNING Read and understand all instructions and warnings prior to installation of the crossmember and towing the trailer.

⚠ WARNING Failure to follow the instructions and heed the warnings of this document may result in death or serious injury, damage to the trailer and/or property, and/or voidance of the product warranty. Always utilize appropriate safety equipment, i.e. proper eye protection, hearing protection, gloves, etc.

⚠ WARNING You are personally responsible for following safe installation procedures, completing appropriate safety checks, and safely towing the trailer.

⚠ WARNING Exercise caution and common sense when lifting and supporting the trailer. Use only appropriately rated support devices that are fit for use. Follow safe trailer supporting procedures recommended by the trailer and support device manufacturers.

DROP-DOWN X-FACTOR CROSSMEMBER

XF12-001 + XF12-003 INSTALLATION INSTRUCTIONS

INSTALLATION

NOTE

Set aside the Inner and Outer Hanger Bracket Adapters from the XF12-001 kit. These will not be used in this installation - they are replaced by the Drop-Down Inner and Outer Hanger Bracket Adapters from the XF12-003 kit.

STEP 1

Support the frame with jacks on each frame rail. Support the axles with floor jacks. While not the easiest method, you can lift and work on one side at a time, if needed.

NOTE

If you are installing the crossmember at the equalizer, it is not necessary to remove the tires as the center bolt can be easily accessed from between the wheels. However, if you are installing the crossmember at the end hangers with the leaf spring, remove the tires to access the hanger bolts.

STEP 2

Remove the shoulder bolt from the frame hanger and replace it with (1) 9/16" wet bolt (shoulder bolt with a grease zerk) included in the XF12-001 installation kit.

The bolt should point toward the inside of the trailer, and the exit hole for the grease should point to the 3 or 9 o'clock position. Use a hammer to tap the wet bolt into the frame hanger. Use a small diameter socket to fit over the grease zerk and tap the bolt in place or remove the zerk, tap the bolt in place, and reinstall the zerk. Do not install the nut until the next step (it is important not to damage the grease zerk).

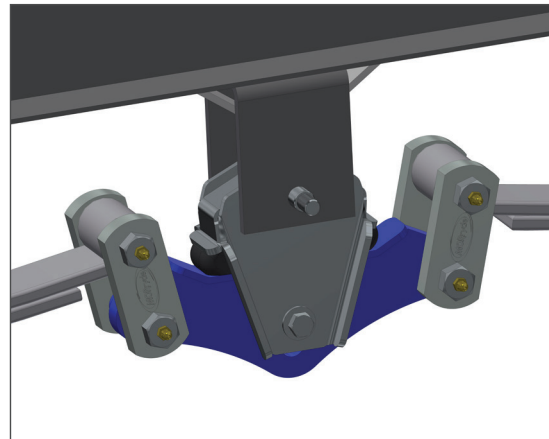

Above. Beyond. Always.

STEP 3

Install the Drop-Down Outer Hanger Bracket Adapter on the trailer frame hanger. Slide (1) Spacer over the end of the 9/16" wet bolt and thread the 7/16" or 1/2" flange nut on by hand. Do not tighten the nut yet.

Insert (2) 5/16" flange bolts through the ears of the Drop-Down Outer Hanger Bracket Adapter. Slide a Spacer Tube over each of the bolts. Next, slide one Hanger Bracket Plate over the ends of each of the bolts on the outside of the frame hanger and install the 5/16" flange nuts. Do not tighten yet.

NOTE

Torque the 7/16" flange nut on the 9/16" wet bolt to 40 ft-lbs with an 11/16" socket while using a 13/16" wrench to hold the bolt in position. Torque the 5/16" flange nuts evenly on each side of the hanger to 20 ft-lbs with a 1/2" socket and wrench.

NOTE

Torque the 1/2" flange nut on the 9/16" wet bolt to 80 ft-lbs with a 3/4" socket while using a 13/16" wrench to hold the bolt in position. Torque the 5/16" flange nuts evenly on each side of the hanger to 20 ft-lbs with a 1/2" socket and wrench.

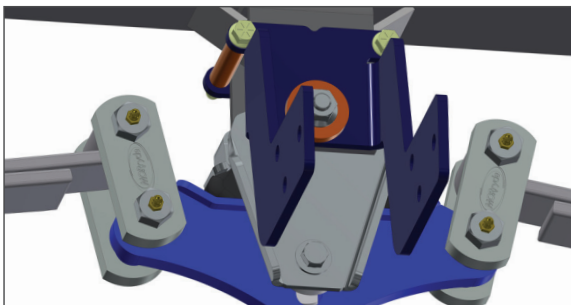

STEP 4

Install the X-Factor Outer Channel onto the Drop-Down Outer Hanger Bracket Adapter using (6) 3/8" flange bolts and 3/8" flange nuts. Hand tighten, but do not torque yet.

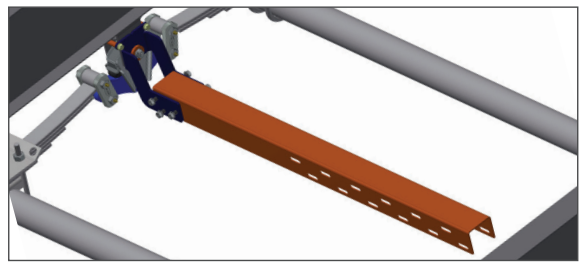

STEP 5

Repeat Steps 2 - 4 for the opposite side with the Drop-Down Inner Hanger Bracket Adapter, X-Factor Inner Channel.

STEP 6

Line up the holes on both crossmember channels and insert (4) 3/8" flange bolts on each side, utilizing the holes farthest from the center in both the top and bottom rows. Install the 3/8" flange nuts.

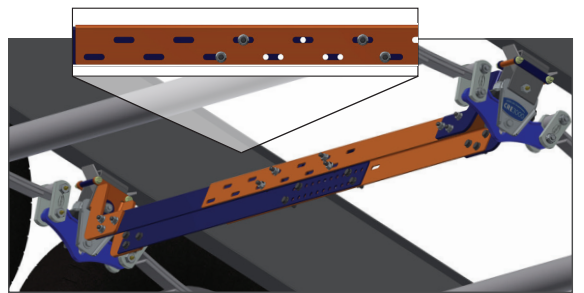

STEP 7

Torque all 3/8" hardware from the previous steps to 40 ft-lbs with a 9/16" socket and wrench.

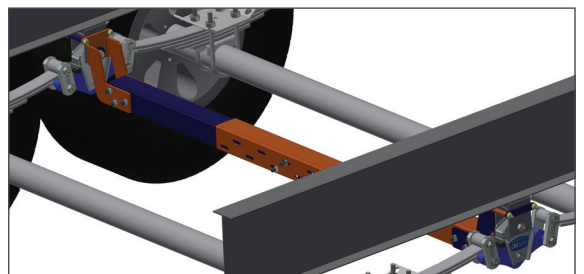

STEP 8

Reinstall tires, if necessary, and torque lug nuts to recommended specifications. Remove the jacks and supports from the frame and axle.

X-FACTOR CROSSMEMBER

INSTALLATION INSTRUCTIONS



Above. Beyond. Always.



X-FACTOR CROSSMEMBER

INSTALLATION INSTRUCTIONS



At MORryde, we have a passion for solving problems. Whether we're fabricating custom solutions, modifying a commercial chassis, or creating our innovative products, we answer to a wide range of markets and deliver on a variety of needs. At MORryde, it's simply about doing MORE for our customers, and it doesn't stop at the sale. We stand behind our products, believing in quality first, service always. No matter the issue, we'll be the first to respond and the last to be satisfied. In short, we build better — together.



Questions? Contact the Parts Department at 574-293-1581 or email parts@morryde.com

X-Factor Crossmember | VERSION 18



Above. Beyond. Always.

