

# TV40-001H

## TELEVISION MOUNT

### INSTALLATION INSTRUCTIONS



Thank you for choosing a MORryde television mount! This sliding base mount is designed to mount flat panel televisions to a horizontal surface and is perfect for inside cabinets or in a corner space.

### Key Features and Benefits

- Slides out 7"
- Up to 200 x 200 VESA pattern
- Swivels up to 140° and tilts 0-15°

#### Range of Motion\*

- Slides out and swivels

### Product and Safety Information

The TV40-001H mounts flat panel televisions or monitors to a horizontal surface.

**NOTE:** This mount is not intended for use on brick, concrete, concrete block.

#### VESA\* Mounting Plates

- 75mm x 75mm
- 100mm x 100mm
- 200mm x 200mm

\* Video Electronics Standards Association

#### Weight Capacity

- 50 lbs

### Parts List

1. Bracket Arm
2. Base Mount
3. Locking Bar
4. TV Bracket
5. TV Mounting Plate
6. Hardware

**⚠ WARNING** Improper installation may cause property damage or personal injury. The mounting surface may require reinforcement as it must be capable of supporting five times the combined weight of the television and the mount.

The installer assumes all responsibility of verifying that any installation method and mounting surface securely support the television and mount. MORryde is not liable for property damage or injury caused by incorrect mounting, installation methods not recommended by MORryde, hardware not provided by MORryde, or incorrect use of the mount during travel or otherwise.

## Preparation

### Television Stand

If applicable, remove the original base stand in accordance with the television owner's manual.

### Hardware

Use appropriate hardware for securing your television to the mount and mounting your television to the mounting surface.



M4x12mm Bolt (4)



M5x12mm Bolt (4)



M6x12mm Bolt (4)



1/4" x 1" Lag Bolt (8)



M6 Flat Washer (8)



#10 Flat Washer (8)



1/4" Flat Washer (8)

## Installation

**⚠ WARNING** Using mounting hardware too long for your application may puncture exterior structures.

**⚠ WARNING** If your television came with a stand, please remove the stand by referring to your television's owners manual and ensure the hardware has been removed from the mounting holes.

### STEP 1

**Assemble mount:** Remove the bolt and lock nut<sup>1</sup> from the bracket arm<sup>2</sup> and slide through the base mount opening<sup>3</sup> until the locking bar<sup>4</sup> catches the front slot<sup>5</sup> ("IN" position). Install the bolt and lock nut<sup>1</sup> back into the desired location (Option A or B to the right).

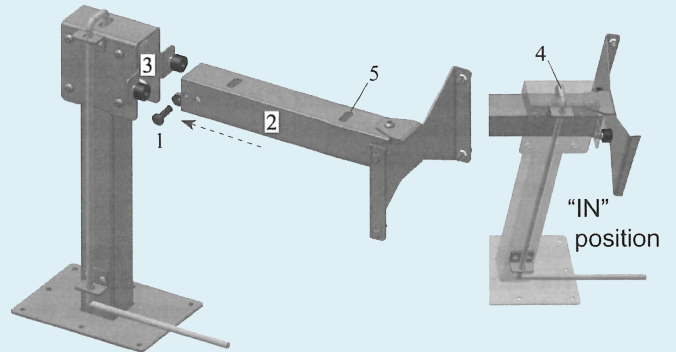

**Option A:** Placing the bolt in the back hole allows for the bracket arm to be locked into place in both the "OUT" and "IN" positions.

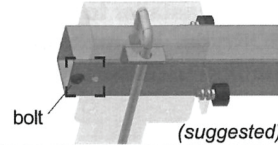

**Option B:** Placing the bolt in the front hole allows the TV to move freely in the "OUT" position and only lock in the "IN" position.

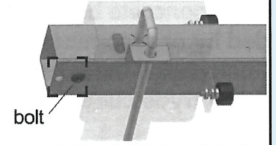

### STEP 2

**Secure the bracket to the mounting surface:**

Pre-drill holes using a 1/8" drill bit for use with 1/4" lag bolts. Use lag bolts or self-drilling screws (depending on your mounting surface) with 1/4" washers to secure base of bracket to the mounting surface.

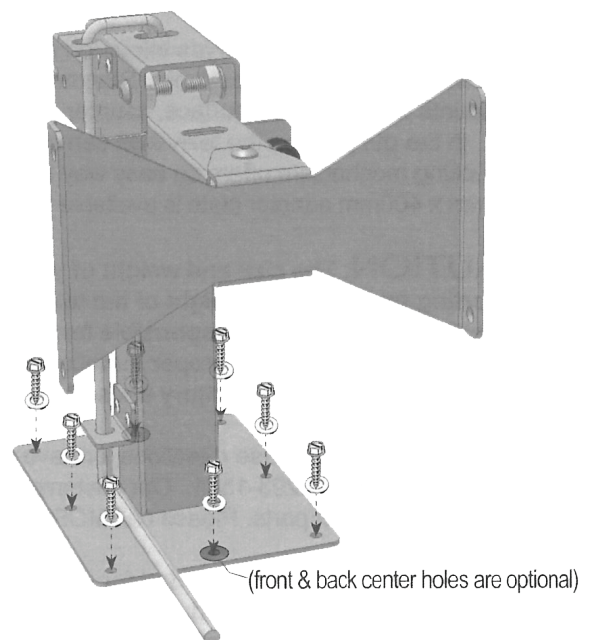

### STEP 3

#### Secure the television to mounting plate:

Line up the hole pattern on your television with the matching hole pattern on the universal mounting plate as close to the center as possible. Use the appropriate hardware to secure the television to the mounting plate.

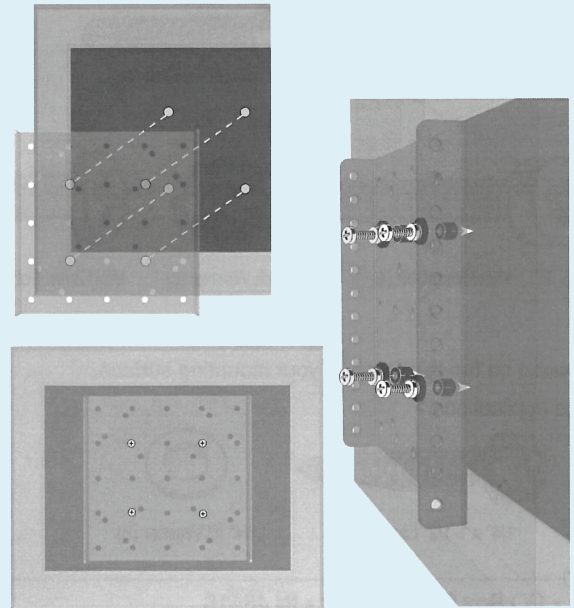

### STEP 4

#### Secure mounting plate with television to bracket arm:

Loosely secure the mounting plate - with the television attached - to the bracket arm. Adjust height for television size and tighten bolts to hold in place.

**⚠ WARNING** Step 4 may require two people to lift the television safely into place. MORryde is not responsible for property damage and/or personal injury due to improper or unsafe installation practices.

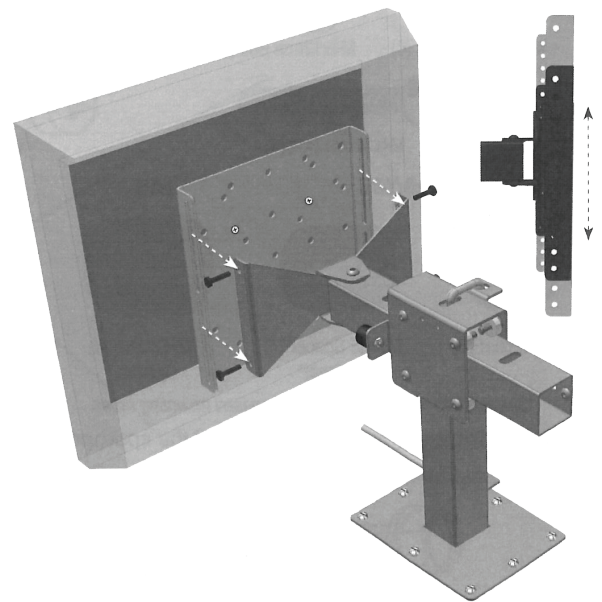

## Warranty

Please Visit [www.MORryde.com](http://www.MORryde.com) for warranty information.

If you have questions about the installation process, please call our customer service department at **574.293.1581** for assistance.



Above. Beyond. Always.

574.293.1581 • [www.MORryde.com](http://www.MORryde.com)

At MORryde, we have a passion for solving problems. Whether we're fabricating custom solutions, modifying a commercial chassis, or creating our innovative products, we answer to a wide range of markets and deliver on a variety of needs. At MORryde, it's simply about doing MORE for our customers, and it doesn't stop at the sale. We stand behind our products, believing in quality first, service always. No matter the issue, we'll be the first to respond and the last to be satisfied. In short, we build better — together.



TV40-001H | VERSION 2



Above. Beyond. Always.

574.293.1581 • [www.MORryde.com](http://www.MORryde.com)