

# TV1-022H

## TELEVISION MOUNT

### INSTALLATION INSTRUCTIONS



Thank you for choosing a MORryde television mount! This extending ceiling mount is designed to mount flat panel televisions or monitors weighing up to 25 lbs. Excellent for under cabinets installation or reinforced ceilings.

### Key Features and Benefits

- Locks in place
- Tilt and swivel adjustment
- No assembly required

#### Range of Motion\*

- Swivel up to 360° and up to 10.5° tilt

\* For most applications

### Parts List

1. TV Plate
2. Base Plate
3. Base Extension
4. Hardware Pack
5. Extension Nut and Bolt

**⚠ WARNING** Improper installation may cause property damage or personal injury. The mounting surface may require reinforcement as it must be capable of supporting five times the combined weight of the television and the mount.

The installer assumes all responsibility of verifying that any installation method and mounting surface securely support the television and mount. MORryde is not liable for property damage or injury caused by incorrect mounting, installation methods not recommended by MORryde, hardware not provided by MORryde, or incorrect use of the mount during travel or otherwise.

### Product and Safety Information

The TV1-022H mounts flat panel televisions or monitors to a flat surface in an outside entertainment center.

**NOTE:** This mount is not intended for use on brick, concrete, concrete block.

#### VESA\* Mounting Plates

- 75mm x 75mm
- 100mm x 100mm

\* Video Electronics Standards Association

#### Weight Capacity

- 25 lbs

## Preparation

### Television Stand

If applicable, remove the original base stand in accordance with the television owner's manual.

### Hardware

Use appropriate hardware for securing your television to the mount and mounting your television to the mounting surface.



M4x12mm Bolt (4)



M5x12mm Bolt (4)



M6x12mm Bolt (4)



1/4" x 1" Lag Bolt (8)



M6 Flat Washer (8)



#10 Flat Washer (8)



1/4" Flat Washer (8)

## Installation

**⚠ WARNING** Using mounting hardware too long for your application may puncture exterior structures.

**⚠ WARNING** If your television came with a stand, please remove the stand by referring to your television's owners manual and ensure the hardware has been removed from the mounting holes.

### STEP 1

Assemble mount:

- a) To add base extension, use hammer to tap spring pin in place.
- b) Slide VESA adapter plate to desired height and secure with nut and bolt.

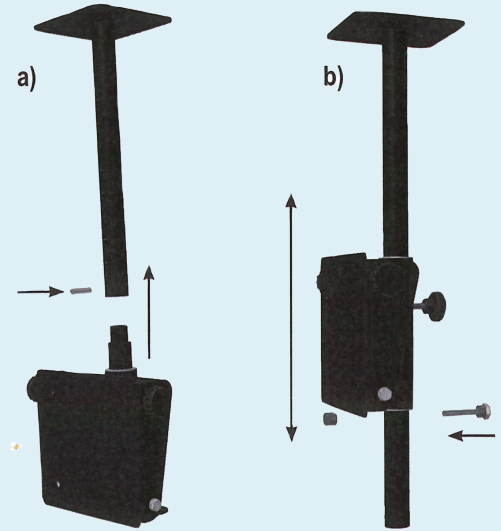

### STEP 2

Secure mount to reinforced ceiling or the mounting

surface: Pre-drill holes using a 1/8" drill bit. Use 1/4" lag bolts and 1/4" washers or appropriate hardware for the structure to secure the mount to the reinforced mounting surface.

Loosen knobs on side to tilt then tighten in place for desired viewing angle.

Loosen knob in back to swivel and then tighten in place for desired viewing angle.

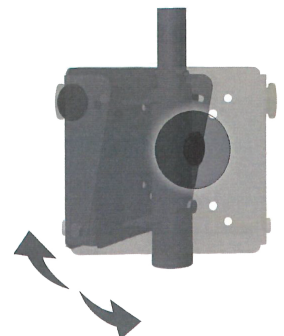
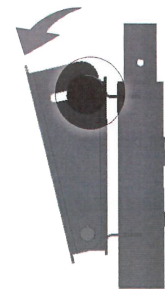
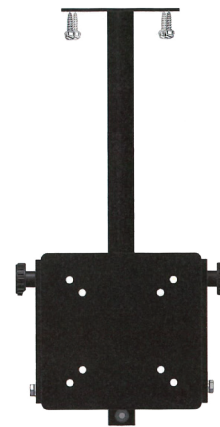

## Installation

**⚠ WARNING** Using mounting hardware too long for your application may puncture exterior structures.

### STEP 3

**Secure the television or monitor to the mount:** Line up the hole pattern on your television with the matching hole pattern on the mounting plate. Use the appropriate mounting hardware to secure the television to the mounting plate.

**⚠ WARNING** Step 3 may require two people to lift the television safely into place. MORryde is not responsible for property damage and/or personal injury due to improper or unsafe installation practices.

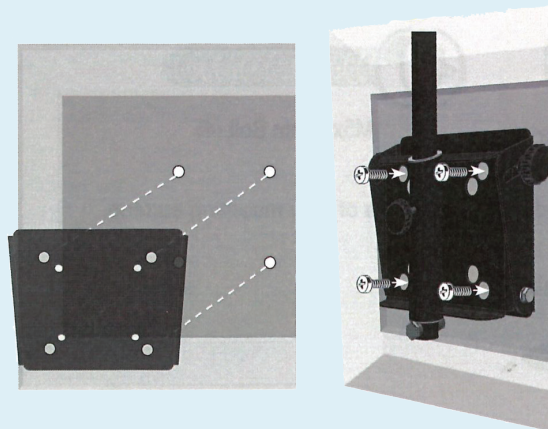

## Warranty

Please Visit [www.MORryde.com](http://www.MORryde.com) for warranty information.

If you have questions about the installation process, please call our customer service department at **574.293.1581** for assistance.



Above. Beyond. Always.

574.293.1581 • [www.MORryde.com](http://www.MORryde.com)

At MORryde, we have a passion for solving problems. Whether we're fabricating custom solutions, modifying a commercial chassis, or creating our innovative products, we answer to a wide range of markets and deliver on a variety of needs. At MORryde, it's simply about doing MORE for our customers, and it doesn't stop at the sale. We stand behind our products, believing in quality first, service always. No matter the issue, we'll be the first to respond and the last to be satisfied. In short, we build better — together.



TV1-022H | VERSION 2



Above. Beyond. Always.

574.293.1581 • [www.MORryde.com](http://www.MORryde.com)