

INSTALLING YOUR EXCURSION RACK FOR SPARE TIRE (JP56-001)

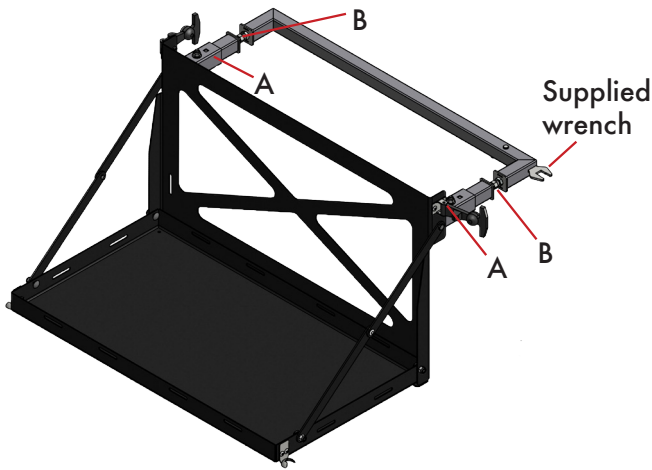

1. Place Excursion rack over the spare tire.

2. Rough adjustment: with a 7/16" wrench, remove the frame bolts (A) and adjust the frame using the bolt holes that provide the closest fit of the frame around the tire. Replace and tighten the bolts.

3. Fine adjustment: using the supplied wrench, spin the turnbuckle adjusters (B) so the frame is a snug fit on the tire. Adjust them until the "L"-shaped pieces of the frame grip the tire firmly.

4. The long ratchet strap is used to secure the rack to the tire - it's best to run the strap around the bottom of the spare mount. Hook the straps to the slots on each side of the rack and use the ratchet strap to tighten the strap to prevent any movement of the rack on the tire. The photo to the left shows this strap angled down about 45 degrees to go around the bottom of the spare mount.

5. The shorter ratchet straps are used to secure cargo to the rack as shown in photo 2 below. There are several slots in the tray to allow for best positioning of the straps to suit the cargo.

6. The weight carried on the rack depends on the strength of your spare mount and the weight of your spare; for a stock Wrangler spare mount and stock weight spare, a maximum of 25-30 pounds is recommended, which is enough to accommodate a large cooler with food and beverages for a party of 4. If your Jeep has an aftermarket spare carrier that's rated for more weight, then the Excursion Rack can be used to carry heavier loads.

NOTE: Compatible with JK, TJ, YJ, and CJ Jeeps

NOTE: 32" maximum tire size is recommended. If your tire size exceeds 32", your rack is more at risk of loosening during travel. In this case, please use ratchet strap (included) to secure excursion rack as seen in picture to left.

