

MEGA/ryde™ by

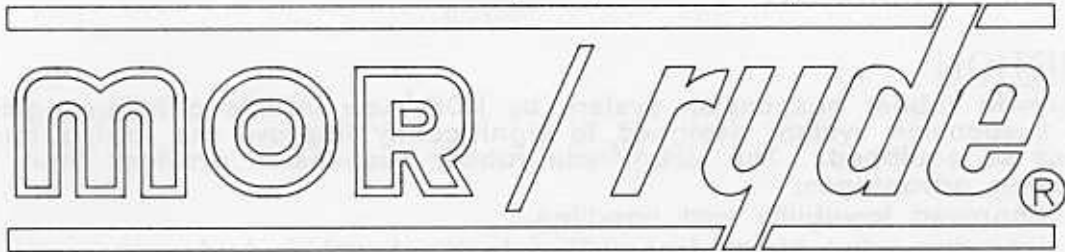

Service Manual

Suspension System: TA2-02, TA2-04, TA3-01

CONTENTS

SECTION	SUBJECT	PAGE
I	Description	2
II	Maintenance	3
	A. Shock Absorber	3
	B. Fastener Maintenance	3
III	Service	3-6
	A. Replacement of Rubber Bushing	3
	B. Replacement of Rubber Spring	4
	C. Replacement of Cap Bolts	5
	D. Replacement of Shock Absorber	5
	E. Replacement of Crossmember	6
IV	Torque Requirements	6

SECTION I

DESCRIPTION

The MEGA/ryde rubber suspension system by MOR/ryde Int'l is a technologically advanced suspension system designed to significantly improve the towing quality of towables so equipped. The MEGA/ryde rubber suspension provides three (3) distinct towing advantages:

1. Improved towability and handling.
2. less damaging stress transmitted to the towables body, components and contents.
3. Reduced body roll for towable vehicle.

This Service Manual will provide information concerning routine preventive maintenance and service instructions. Following these instructions will help ensure that MEGA/ryde will provide thousands of safe and trouble free miles.

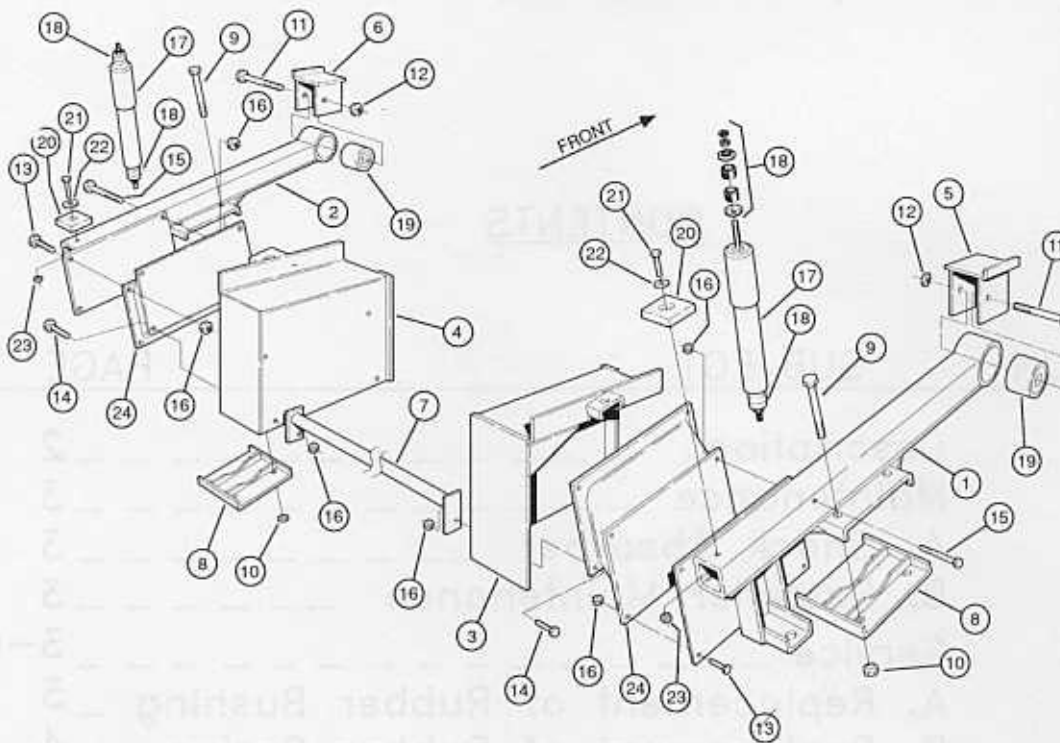

Item No.	Part No.	Description	Item No.	Part No.	Description
1	TA10-005	Beam Assembly RH	13	UO115-011	Bolt; .38-16 x .88 HHCB GR5
2	TA10-006	Beam Assembly LH	14	UO115-003	Bolt; .38-16 x 1.25 HHCB GR5
3	TA11-012	Rear Hanger Assembly RH	15	UO115-016	Bolt; .38-16 x 3.0 HHCB GR5
4	TA11-013	Rear Hanger Assembly LH	16	UO116-002	Nut; .38-16 Hex LK
5	TA11-010	Front Hanger Assembly RH	17	UO109-001	Shock Absorber
6	TA11-011	Front Hanger Assembly LH	18	P861	Shock Fastener
7	TA21-*	Cross Member Assembly	19	GO128-006	Rubber Bushing
8	TA15-002	Axle Retaining Pad	20	TA133-001	Rubber Jounce Bumper
9	UO115-030	Bolt; .63-11 x 5.5 HHCB GR8	21	UO115-010	Bolt; .25-20 x 1.0 HHCB GR2
10	UO116-006	Nut; .63-11 Hex LK	22	UO117-010	Washer, .25 ID GR8
11	UO115-001	Bolt; .75-10 x 3.5 HHCB GR5	23	UO116-010	Nut; .25-20 Hex LK
12	UO116-001	Nut; .75-10 Hex LK	24	TA108-**	Rubber Spring

*Cross member assembly part number is determined from the frame rail width.

**Rubber spring part number is determined from the gross axle weight rating (GAWR). 5,200#-TA108-002, 6,000#-TA108-003, 7,000#-TA108-001.

SECTION II

MAINTENANCE

The MEGA/ryde suspension utilizes MOR/ryde's unique 100% natural rubber springs and rubber bushings. The rubber springs do not require lubrication, and maintenance is limited to periodic inspections to insure the rubber bushings and springs are intact.

II-A SHOCK ABSORBER MAINTENANCE

The shock absorbers used on the MEGA/ryde rubber suspension are specially valved and made specifically for MOR/ryde. The shock absorbers should be checked every 10,000 miles to make sure they are functioning properly, the bushings are not worn, and the dust cover has not been damaged by road debris or stones. If a shock absorber is leaking or fails to operate, the complete unit should be replaced. The shock absorbers can be ordered direct from MOR/ryde. See Section III-D for replacement procedures.

II-B FASTENER MAINTENANCE

The bolts and nuts should be periodically checked for proper torque—please see torque chart for proper specifications (Section IV).

SECTION III

III-A REPLACEMENT OF RUBBER BUSHINGS

- 1.) Make sure towable is elevated, the frame is supported with safety stands, and the suspension is hanging unsupported.
- 2.) Elevate axle with floor jack and safety stands.
- 3.) Remove tire on side of vehicle in which rubber bushing is to be replaced.
- 4.) Remove 3/4" pivot bolt from bushing end of beam.
- 5.) Rotate beam assembly (See Figure 1) to reveal rubber bushing.
- 6.) Remove rubber bushing from end of beam. Note, Figure 1 depicts one possible process to remove the bushing from the beam using a c-clamp and suitable spacer.
- 7.) Insert new rubber bushing into beam assembly.
- 8.) Rotate beam assembly to its original position, insert 3/4" pivot bolt.
- 9.) Torque pivot bolt to proper specifications (See Section IV).
- 10.) Install tires, remove jacks and stands.

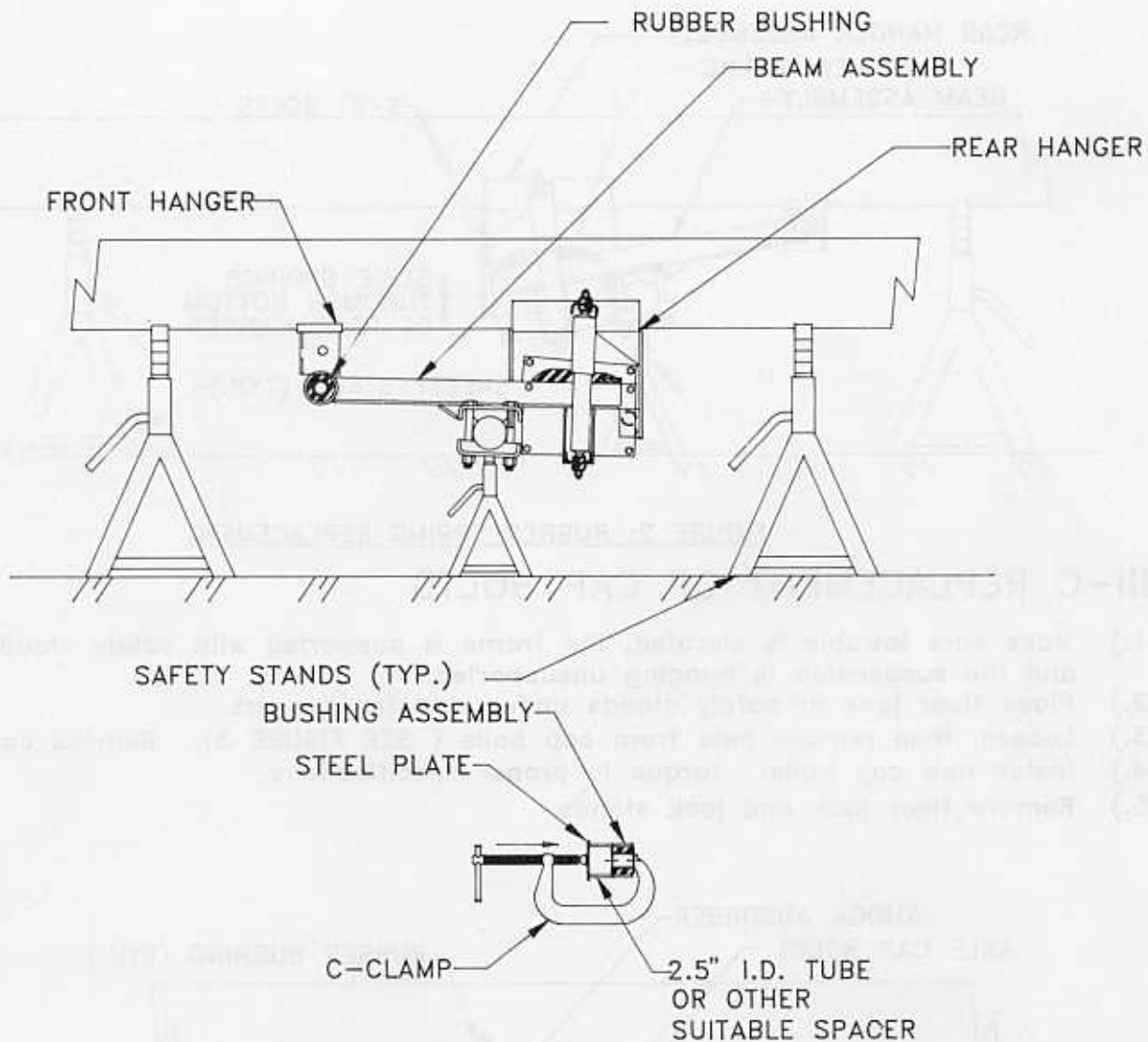

FIGURE 1: BUSHING REPLACEMENT INSTRUCTIONS

III-B REPLACEMENT OF RUBBER SPRINGS

- 1.) Make sure towable is elevated, the frame is supported with safety stands, and the suspension is hanging unsupported.
- 2.) Elevate axle with floor jack and safety stands.
- 3.) Remove tire on side of vehicle in which rubber spring is to be replaced.
- 4.) Remove 3/8" bolts (SEE FIGURE 2) that secure rubber springs to beam and rear hanger assembly.
- 5.) Slide rubber spring out through bottom of hanger assembly.
- 6.) Install new rubber spring. Secure with 3/8" bolts, torque to proper specifications.
- 7.) Install tires. Remove jack stands.

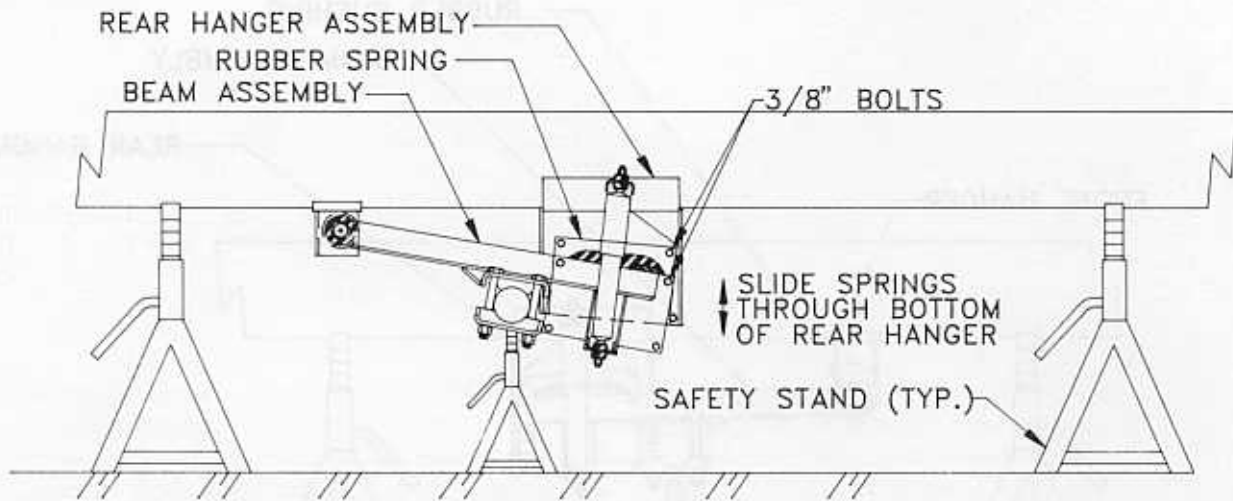

FIGURE 2: RUBBER SPRING REPLACEMENT

III-C REPLACEMENT OF CAP BOLTS

- 1.) Make sure towable is elevated, the frame is supported with safety stands, and the suspension is hanging unsupported.
- 2.) Place floor jack or safety stands under axle for support.
- 3.) Loosen, then remove nuts from cap bolts (SEE FIGURE 3). Remove cap bolts.
- 4.) Install new cap bolts. Torque to proper specifications.
- 5.) Remove floor jack and jack stands.

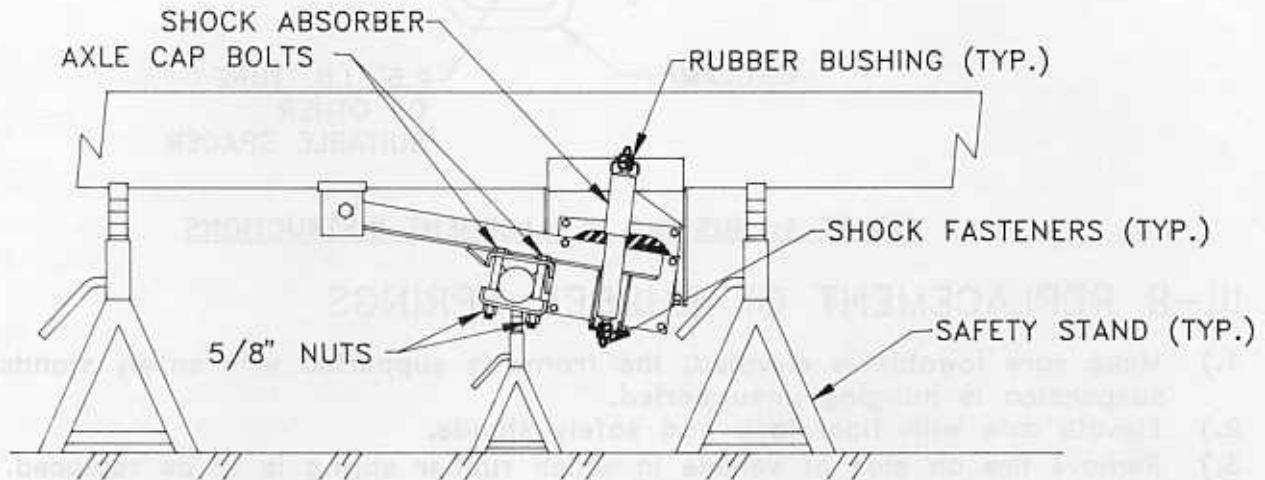

FIGURE 3: SHOCK ABSORBER AND AXLE CAP BOLT REPLACEMENT

III-D REPLACEMENT OF SHOCK ABSORBERS

The MEGA/ryde suspension utilizes 2 specially valved shock absorbers on each axle. Replacement shock absorbers are available direct from MOR/ryde.

To replace a shock absorber:

- 1.) Remove shock fasteners and rubber bushings shown in Figure 3.
- 2.) Remove shock absorber.
- 3.) Install new bushings on new shock absorber.
- 4.) Install new shock absorber.
- 5.) Torque fasteners per torque chart.

III-E REPLACEMENT OF CROSSMEMBER

- 1.) Remove 3/8" bolts securing cross member to hanger assembly. Remove crossmember.
- 2.) Install new cross member. NOTE: Crossmember tube must be positioned above 3/8" bolt. Crossmember tab must be flush with end of rear hanger assembly. See Figure 4 for proper orientation of cross member.
3. Tighten bolts to proper torque specification.

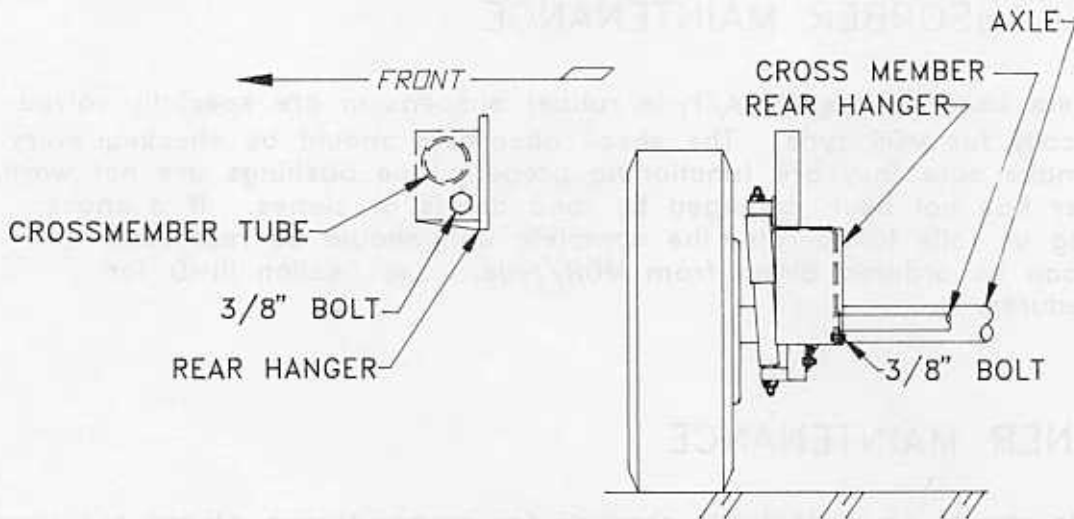

FIGURE 4: CROSSMEMBER REPLACEMENT INSTRUCTIONS

SECTION IV

Torque Requirements

Shown is the torque requirements for bolts used on the MEGA/ryde.

TORQUE CHART FOOT-LBS ± 10%		
BOLT SIZE	GRADE 5	GRADE 8
.25 - 20	7	10
.38 - 16	24	30
.44 - 14	38	45
.5 - 13	50	68
.63 - 11	95	115
.75 - 10	60	

USE ABOVE TORQUE VALUES UNLESS OTHERWISE SPECIFIED ON INSTALLATION PRINT

NOTE: TORQUE VALUE MUST BE VERIFIED WITH A TORQUE WRENCH. A CALIBRATED PNEUMATIC IMPACT WRENCH IS NOT AN ACCEPTABLE SUBSTITUTE.