

MOR/ryde Steer Axle Suspension System

(Double Eye Leaf Spring)

Steer Axle Installation Instructions



MOR/ryde International
1966 Moyer Avenue
Elkhart, IN 46516
574-293-1581

www.morryde.com

SRL153-001 REV.

MOR/ryde Steer Axle Installation Instructions

Instructions will assume procedures apply to both sides of vehicle.

TYPICAL STEER AXLE SUSPENSION KIT

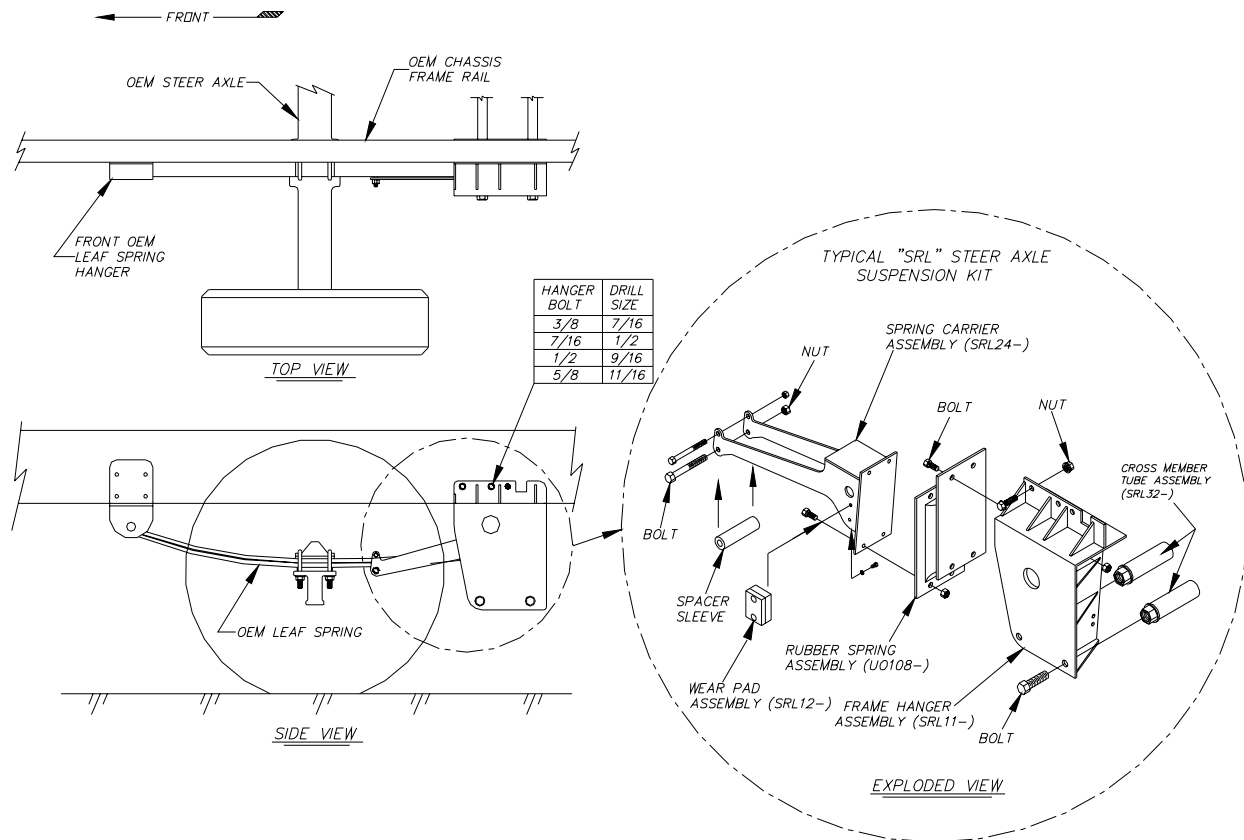

Required Tools for Installation of MOR/ryde Steer Axle Suspension Kit

- | | |
|---|--------------------------|
| *Floor Jack | Pneumatic Air Chisel |
| *Safety Stands | Screwdriver |
| Socket Set | Drift Pin |
| 9/16" Swivel Socket | Large C-Clamp (6" min.), |
| Wrench Set | Porta-Power, |
| Cutting Torch | Small Pipe Clamp |
| Hand Drill | |
| 1/2" Drill Bit | |
| **Reciprocating Saw | |
| **Wire Welder | |
| * Check for Adequate Capacity. It must support the weight of the rear of the vehicle. | |
| ** May be Required for Tailpipe Modifications | |

U.S.A. Patent Number 6,176,478

Torque Chart Foot-LBS +/- 10%

Bolt Size	Grade 5	Grade 8
1/4 - 20	7	10
5/16-18	14	20
3/8-16	25	35
7/16-14	40	55
1/2-13	60	90
5/8 - 11	115	170
5/8-18	125	185
3/4 - 10	190	280



Step 1

Block rear drive axle wheels with suitable wheel chocks. Set park brake and be sure transmission is set in park.



Step 2

Place a floor jack under front steer axle and raise front wheels approximately off the ground.

Be sure jack stands and floor jacks have sufficient capacity to safely support vehicle.



Step 3

Place suitable jack stands approximately 18" behind end of the leaf spring hangers under the main frame rails.



Step 4

Lower the floor jack so the leaf springs are unloaded. The floor jack should remain under the axle. Be sure the frame is securely supported with the jack stands squarely under the frame.



Step 5

Typically the rear leaf spring frame hangers are bolted or riveted to the frame. Remove the leaf spring eye bolt or shackle link. See next pictures. After releasing the leaf spring eye remove the bolts securing the frame hanger. Typically there are bolts through the vertical web and lower flange of the frame. Also remove the rear band clamp around the leaf spring.



Step 6A

The shackles will be either pinned with a link (A) or bolted (B). If pinned remove the link then remove the shackle from the hanger and leaf spring eye. If shackle is bolted to the hanger and leaf spring eye, remove the spring eye bolt. If shackle is pinned MOR/ryde will provide the spring eye bolt, if unit is equipped with a spring eye bolt it should be re-used.



Step 6B



Step 7

Rear leaf spring hanger, rear leaf spring band clamp, and shackle removed. Chassis frame and leaf spring are now ready for the installation of the MOR/ryde components. The frame hanger bolt holes should be reamed out to 1/2" diameter.



Step 8

Position and install MOR/ryde Spring Carriers onto leaf spring. If a spring eye bolt was not provided reuse the factory eye bolt. The spring eye bolt head and Wear Pad should face outboard. Install the 3/8" nut and bolt into the top leading portion of the Spring Carrier. This will prevent the Spring Carrier from rotating down and getting in the way.



Step 9

Using the 1/2" flange bolts provided, position and install the Frame Hanger Assembly. **Start but do not tighten the nuts at this time.** Notice how the plastic Wear Pad is positioned towards the face plate of the Frame Hanger. This picture shows a roadside (driverside) installation. Repeat installation on curbside (passengerside).



Step 10

Using the 3/4" bolts attach the Cross-members between the face plates of the Frame Hanger. At this time tighten all the 1/2" Frame Hanger bolts and 3/4" Cross-member bolts. See torque specs for recommended torques.



Step 11

Bolt the 11" plate of the MOR/ryde Rubber Spring to the back of MOR/ryde Frame Hanger, note Rubber Spring offset is downward towards the MOR/ryde Spring Carrier. Install and tighten all (4) 3/8" bolts at this time. Repeat procedure on opposite side. With a Porta-Power and alignment pins, bolt the Spring Carrier to the 10" Rubber Spring metal. If a Porta-Power is not available, raise or lower the axle to align the plates. It works best to install the 2 lower bolts first on both sides, then raise the axle to close the gap between the top plates. A Vise-Grip or snap clamp may also be useful to squeeze the top plates together prior to installing bolts.



Step 12

Using a Porta-Power or C-clamp apply force to the bottom portion of the Spring Carrier to lower the nose of the Spring Carrier. Install the spacer sleeve and 1/2" bolt under the leaf spring. Install nut and remove C-clamp or push rod.



Step 13



Step 14

Check all nuts and bolts for proper torque. Refer to the torque chart on the 2nd page. Raise axle, remove jack stands and lower unit. There should be approximately 1/8" clearance between plastic Wear Pad and Hanger face plate. Also the spring metal on the Spring Carrier should be approximately 1" lower than the spring metal on the Frame Hanger.