

WWW.MORRYDE.COM

THE MOR/RYPDE RE SYSTEM WORKS WITH THE EXISTING LEAF SPRINGS AND AXLES BUT REPLACES THE STEEL LEAF SPRING EQUALIZER.

THE MOR/RYPDE RE SYSTEM PROVIDES BETTER PROTECTION OF YOUR TRAILER WITH UP TO A 30% IMPROVEMENT IN THE DAMPENING OF ROAD SHOCK.

MOR/RYPDE'S TIP-TO-TAIL SOLUTIONS CREATE A SMOOTHER RIDE THAT DRIVER AND PASSENGERS CAN FEEL.

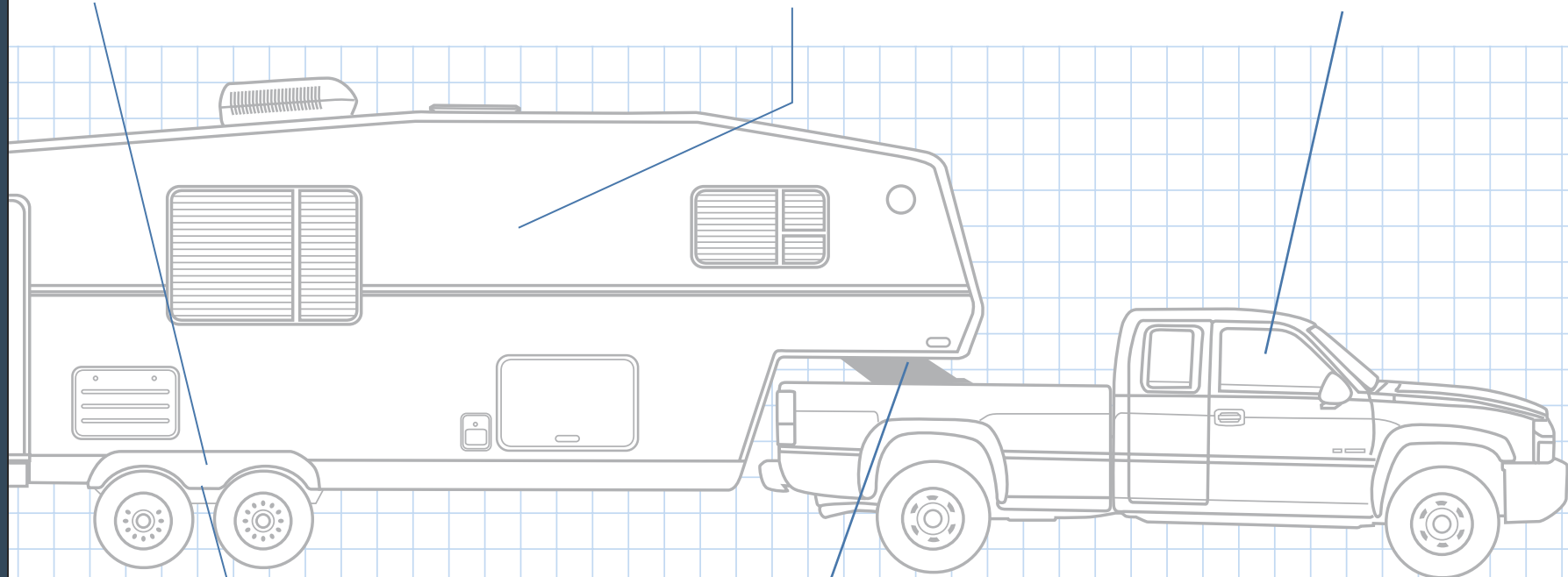

THE MOR/RYPDE RE SYSTEM ISOLATES AND ABSORBS ROAD SHOCK AND INCREASES THE DYNAMIC TRAVEL OF THE LEAF SPRING SUSPENSION.

THE MOR/RYPDE PIN BOX GREATLY REDUCES CHUCKING AND JERKING MOTIONS AND TAKES THE HARSHNESS AWAY FROM TOWING.



SMOOTHING OUT THE ROUGH SPOTS.

YOUR LOCAL DEALER:



SMOOTHING OUT THE ROUGH SPOTS.

MOR/ryde® INTERNATIONAL
1966 Moyer Avenue
P.O. Box 579
Elkhart, Indiana 46515-0579

Phone: 574.293.1581
Fax: 574.294.4936
www.morryde.com

SMOOTH SOLUTIONS

MOR/RYPDE® PRODUCTS FOR SMOOTHER TOWING, RIDING & BRAKING



SMOOTHING OUT THE ROUGH SPOTS.

SOLUTIONS FOR SMOOTHER TOWING

WWW.MORRYDE.COM

MOR/ryde Pin Box System*

Towing a fifth wheel? Tired of that harsh, jerky, back-and-forth motion that puts a strain on the driver, your truck and your fifth wheel? Leave rough towing behind with MOR/ryde's revolutionary Pin Box System. Its advanced rubber shear spring works to absorb towing shock for more comfortable, stress-free travel.

Our Pin Box System provides:

- ▶ GREATLY REDUCED BACK-AND-FORTH CHUCKING AND JERKING
- ▶ CUSHIONED SENSATION OVER UNEVEN ROAD CONDITIONS
- ▶ SMOOTHER, MORE COMFORTABLE IN-CAB RIDE
- ▶ CLUNK-FREE STARTS AND STOPS

Installation: Our Pin Box System is available for installation in the aftermarket – or can be ordered from select manufacturers on new units – and installs in an hour on most fifth wheels.



UNIQUE SPRING ABSORBS SHOCK.

Our rubber shear spring works in a horizontal planar motion (both longitudinally and laterally) to absorb towing shock and effectively diminish the transfer of forces from trailer to truck. See our Pin Box System in action at www.morryde.com.

*Patent Pending

MOR/ryde IS (Independent Suspension) System**

Do your RV adventures include some unwanted rough spots? Like broken dishes and scattered furniture? Pushing, pulling and swaying while towing? Continuous bouncing on interstate highways? Broken leaf springs and worn shackles? MOR/ryde's Independent Suspension (IS) System is uniquely engineered to smooth out those highway jolts and jars from towing a fifth wheel or travel trailer.

Our IS System provides:

- ▶ ADVANCED RUBBER SPRING TECHNOLOGY FOR SMOOTH, STABLE TOWING
- ▶ INDEPENDENT WHEEL ACTION WALKS OVER BUMPS AND CHUCKHOLES
- ▶ PROTECTION FOR TRAILER'S STRUCTURAL INTEGRITY AND ITS CONTENTS
- ▶ INCREASED SUSPENSION TRAVEL TO HELP ABSORB IMPACT

Installation: If you're buying a new vehicle, ask for MOR/ryde's IS System by name at your dealer. If you're looking for a retrofit, we can provide expert installation at the MOR/ryde Factory Service Center.

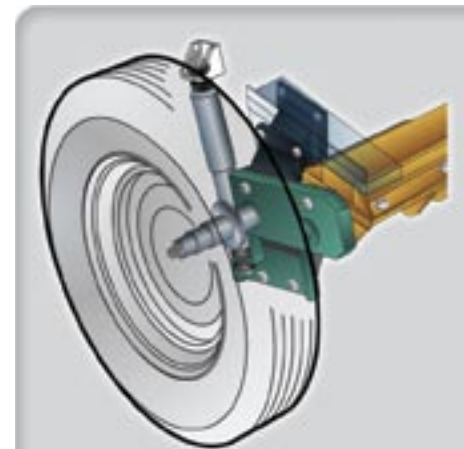

"WALK OVER" BUMPS.

The MOR/ryde IS system totally replaces the axles and springs to deliver premium performance. It features independent wheel action and 5 1/2" of suspension travel that allows each wheel to "walk over" road bumps. The result is exceptional towing smoothness.

**United States Patent Number: 5,899,470

MOR/ryde RE (Rubber Equalizer) Suspension System*

Do less traveled roads or even interstate highways cause damage to your trailer, not to mention your disposition? That's because a typical RV leaf spring suspension system can't adequately handle the job, sending jarring road shocks straight into the frame of your trailer and its contents. MOR/ryde's Rubber Equalizer (RE) Suspension System is the affordable way to upgrade, by replacing the steel spring equalizer with rubber shear springs to absorb more road shock and increase suspension travel.

Our Rubber Equalizer Suspension System provides:

- ▶ SMOOTHER TOWING THAN CONVENTIONAL LEAF SPRINGS
- ▶ BETTER PROTECTION OF YOUR TRAILER INVESTMENT
- ▶ UP TO A 30% IMPROVEMENT IN DAMPENING OF ROAD SHOCK
- ▶ AFFORDABLE LEAF SPRING SUSPENSION UPGRADE

Leading fifth wheel and travel trailer brands recognize MOR/ryde RE as the top choice in suspension systems.



MAKING YOUR LEAF SPRINGS WORK BETTER.

The MOR/ryde RE (Rubber Equalizer) System isolates and absorbs road shock, offering increased suspension travel.

*United States Patent Number 6,478,321

MOR/ryde RL (Rubber Leaf) Suspension System**

Feeling every bump in the road while in your truck, especially when you're not hauling a load or towing your trailer? Does its stiff, unforgiving suspension send all the jolts and jars right to the frame and into the cab? There's a way to actually love your truck's ride as much as you love your truck – MOR/ryde's RL Suspension System. Its unique rubber shear springs absorb road impact and reduce the shock transmitted to your truck.

Our Rubber Leaf Suspension System provides:

- ▶ PROTECTION FROM JARRING EFFECTS OF UNEVEN ROADS
- ▶ MUCH SMOOTHER TRUCK RIDE
- ▶ IMPROVED DRIVER AND PASSENGER COMFORT

Installation: Our RL Suspension System is compatible with most medium and heavy-duty pickup trucks. It can be ordered factory-direct and installed by a qualified technician or at the MOR/ryde Factory Service Center.



YOUR TRUCK DOESN'T HAVE TO RIDE LIKE ONE.

The MOR/ryde RL (Rubber Leaf) Suspension System isolates and absorbs road shock, providing for a smoother, more compliant ride.

**United States Patent Number: 6,176,478

MOR/ryde Running Gear Upgrades

Concerned that your original electric trailer brakes won't let you stop when you need to stop? Not sure what will happen in a panic stop situation or when traveling down a steep grade? For peace of mind, just bring your rig to MOR/ryde for professional analysis and reliable information. We not only specialize in suspension systems, but also running gear upgrades including disc brakes, electric brake replacement, and Nev-R-Lube™ sealed cartridge bearings.



ELECTRIC BRAKES

If you want to replace your electric brakes, we have a complete line, including 12 x 2, 12 1/4 x 2 1/2, and 12 1/4 x 3 3/8 with capacities up to 8000 pounds.



DISC BRAKES

For maximum safety, MOR/ryde recommends automotive-style disc brakes that provide up to a 25% shorter stopping distance and reduced heat and brake fade.



NEV-R-LUBE™ BEARINGS

These sealed cartridge bearings carry a 100,000-mile warranty, eliminating the need for annual bearing maintenance, and are available on 12 x 2, 12 1/4 x 2 1/2 and 12 1/4 x 3 3/8 electric brakes and disc brakes.

WHY KEEP ROUGHING IT? SMOOTH SOLUTIONS ARE AT WWW.MORRYDE.COM

The entire MOR/ryde product line can be summed up in a single word – smooth. We offer a variety of solutions for smoother towing, smoother riding and smoother braking. We also provide expert advice and professional installation to make the entire process go more smoothly for you.

To start smoothing out the rough spots in your RVing, take a trip to www.morryde.com.

You'll find:

- ▶ ANIMATIONS OF OUR PRODUCTS IN ACTION
- ▶ DETAILED PRODUCT BROCHURES TO DOWNLOAD
- ▶ LATEST NEWS FROM MORRYDE
- ▶ CUSTOMER TESTIMONIALS

FOR MORE DETAILS ON ANY MORRYDE PRODUCT, VISIT WWW.MORRYDE.COM OR CALL 574-293-1581.



SMOOTHING OUT THE ROUGH SPOTS.