

# MOR/ryde Drive Axle Suspension System

(Double Eye Leaf Spring)  
RL Installation Instructions



MOR/ryde International  
1966 Moyer Avenue  
Elkhart, IN 46516  
574-293-1581

[www.morryde.com](http://www.morryde.com)

# MOR/ryde "RL" Installation Instructions

Instructions will assume procedures apply to both sides of vehicle.

## TYPICAL "RL" DRIVE AXLE SUSPENSION KIT

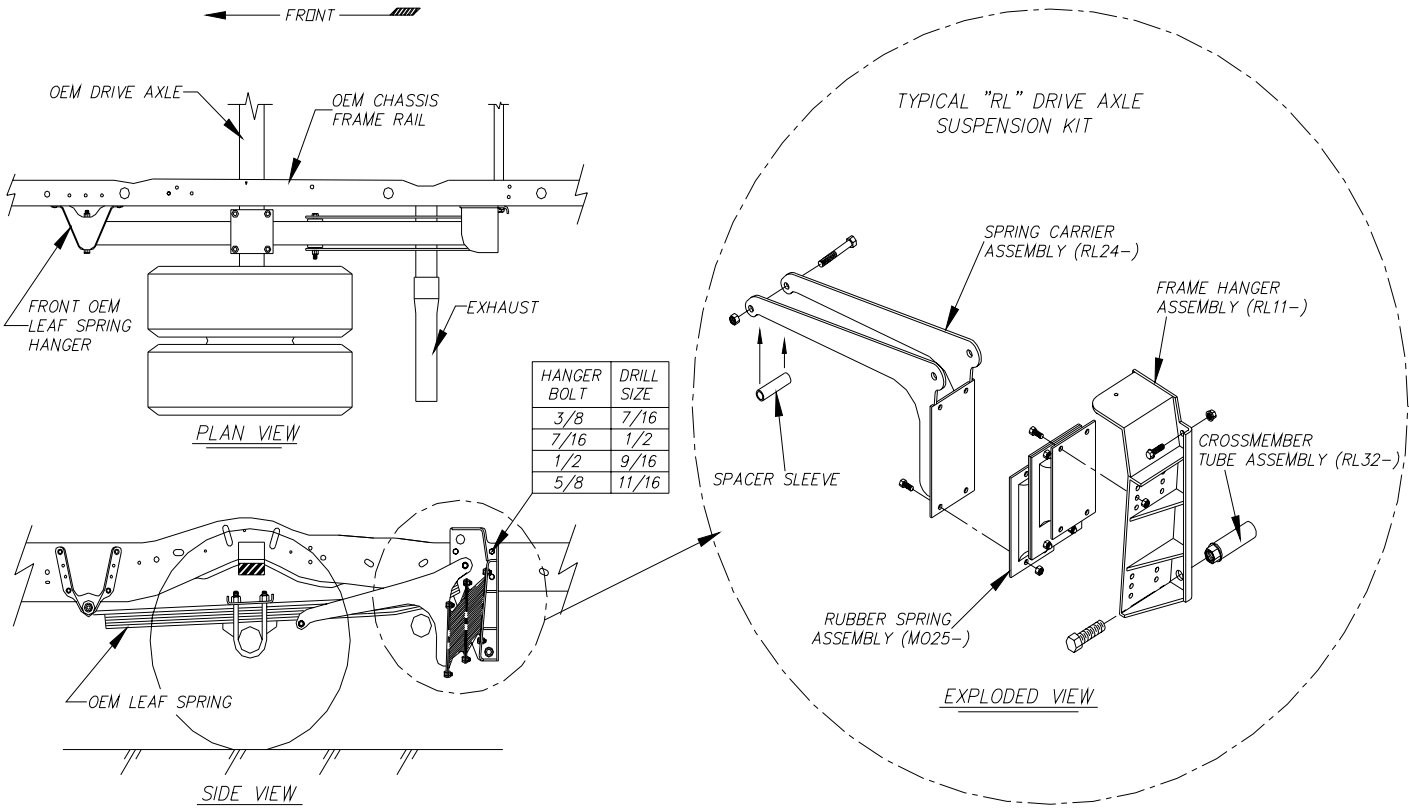

U.S.A. Patent Number 6,176,478

Required Tools for Installation of MOR/ryde "RL" Suspension Kit	
*Floor Jack	Pneumatic Air Chisel
*Safety Stands	Screwdriver
Socket Set	Drift Pin
9/16" Swivel Socket	MOR/ryde Installation Tool
Wrench Set	or
Cutting Torch	Large C-Clamp (6" min.),
Hand Drill	Porta-Power,
1/2" Drill Bit	Small Pipe Clamp
**Reciprocating Saw	
**Wire Welder	
* Check for Adequate Capacity. It must support the weight of the rear of the vehicle.	
** May be Required for Tailpipe Modifications	

Torque Chart		
Foot-LBS +/- 10%		
Bolt Size	Grade 5	Grade 8
1/4 - 20	7	10
5/16-18	14	20
3/8-16	25	35
7/16-14	40	55
1/2-13	60	90
5/8 - 11	115	170
5/8-18	125	185
3/4 - 10	190	280



Step 1

Place floor jack under differential and raise drive axle tires to approximately 6" off the ground.



Step 2

Place jack stands underneath OEM frame and release floor jack. Drive axle tires should be approximately 1" off ground.

Be sure jack stands and floor jacks have sufficient capacity to safely support vehicle.



Step 3

The exhaust pipe can not be closer than 1" from metal parts and no closer than 2" from the rubber parts of the MOR/ryde system. If alteration of the exhaust is expected, cut exhaust just behind the drive axle leaving 1-1/2" of straight flat pipe. The exhaust will be rejoined at a later time. If no exhaust alteration is expected go to Step 4.



Step 4

To facilitate installation one may want to remove the spare tire or fuel tank. Remove rear spring eye shackle nut and bolt. If possible, raise drive axle and remove shackle nut and bolt over top of frame. If spring hanger is above leaf spring eye, lower leaf spring to remove spring eye bolt.

**Note: Save spring eye nut and bolt for use later.**



Step 5

If the OEM spring hanger is riveted onto the frame, remove the rivets with an air chisel or a cutting torch (usually 4-8 rivets). If the hanger is bolted on, remove it with the appropriate tools.

**DANGER:** Gasoline is very flammable. Be sure that the fuel cell, fuel lines and wire harnesses are adequately protected from sparks.



Step 6

If the shackle was not removed in step 4, lower the spring eye below the frame and remove the shackle bolt and nut.



Step 7

With the appropriate drill bit (see parts list), ream the existing spring hanger hole to be sure that the hole is clear of any debris. These holes will be used to bolt the MOR/ryde frame hanger to the OEM chassis.



Step 8

Frame and leaf spring are now ready for installation of MOR/ryde components.



Step 9

Carefully inspect the MOR/ryde spring carrier assemblies for an offset spring plate. If an offset is observed, position the largest offset away from the OEM frame rail. Refer to the diagram below. This will achieve the greatest clearance between the spring plate and the OEM frame rail. Re-use the spring eye nut and bolt to install the MOR/ryde spring carrier, except on the Ford E350 & E450 chassis.\* The bolt head must be installed towards the OEM frame rail.

\*Note: On Ford E350 & E450 kits, use new spring eye bolt and nut provided.

MOR/ryde spring carrier

Offset side

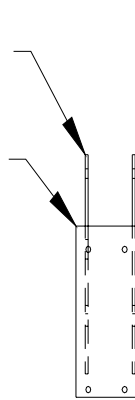

OEM frame rail.

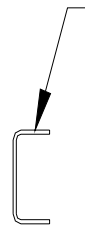

Step 10

Bolt the MOR/ryde frame hanger to the chassis frame through the existing holes that were reamed in step 7. Use the mounting hardware provided by MOR/ryde. The fuel cell may need to be lowered to install the frame hanger nuts. A long handled socket wrench and mechanical fingers may be helpful. The nuts must be installed on the inside of the chassis frame. Do Not tighten the nuts at this time.



Step 11

If your kit is equipped with a cross member, install the MOR/ryde cross member between the frame hangers with the bolts provided. Tighten the frame hanger and cross member bolts at this time. Note the torque requirements on page two.



Step 12

Bolt the MOR/ryde Rubber Spring Assembly to the Frame Hanger using hardware as provided. Note three ride height options on the Frame Hanger, a lower hole setting will raise the vehicle. A top hole setting will lower the vehicle.



Step 13

Using a bottle jack, position jack head under MOR/ryde Rubber Spring Assembly.



Step 14

Raise Rubber Spring to align holes through Spring Carrier. Drift pins can be used to aid in aligning the holes.



Step 15

Bolt Rubber Spring Assembly to Spring Carrier using hardware as provided.

Note: If you have a MOR/ryde Installation Tool and lobes are present,(Refer to diagrams below) proceed to Step 16. If you do not have a MOR/ryde Installation Tool proceed to Step 20 for a C-Clamp installation or Step 21 for a Porta-Power installation.

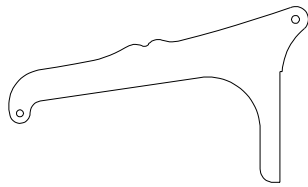

With Lobes

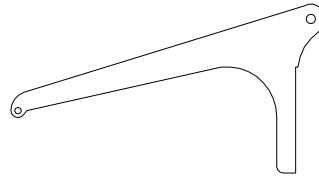

Without Lobes



Step 16

Be sure threaded rod on MOR/ryde Installation Tool has a liberal coat of grease before proceeding. Position Installation Tool onto Spring Carrier between raised lobes as shown. Rotate threaded rod on Installation Tool to rotate Spring Carrier legs down.



Step 17

Tighten Installation Tool bolt until Spacer Sleeve/ Pad hole "A" on Spring Carrier leg is approximately 1" below leaf spring.



Step 18

Position MOR/ryde Spacer Sleeve/Pad between Spring Carrier legs under leaf spring and install bolt and lock nut through Spring Carrier legs and Spacer Sleeve/Pad. Bolt should be installed from under the chassis frame outward so lock nut is positioned between leaf spring and tire.

Do not over tighten lock nut. With Spring Carrier legs just contacting ends of Spacer Sleeve/Pad, apply 50% of the suggested torque as shown on the torque chart on page 2.



Step 19

Remove Installation Tool. Be sure Spacer Sleeve/ Pad is flat against leaf spring at normal vehicle weight. Check this after unit is sitting on ground. If required, rotate Spacer Sleeve/Pad to bear flat against leaf spring. Be sure bolt head faces towards frame. Go to step 22.



Step 20

**C-Clamp Method**  
Position C-clamp between lower portion of Spring Carrier and Frame Hanger as shown. Tighten C-clamp until nose of Spring Carrier is positioned under leaf spring. Install 1/2" bolt and Spacer Sleeve/Pad between legs of Spring Carrier. Be sure bolt head faces towards frame.



Step 21

**Porta-Power Method**  
Position Porta-Power between lower portion of MOR/ryde Spring Carrier and rear of axle. Pump Porta-Power until nose of Spring Carrier drops below the leaf spring. Install 1/2" bolt and Spacer Sleeve/Pad between legs of Spring Carrier. Be sure bolt head faces towards frame.



Step 22

Tighten spring eye bolt.

Repeat procedure on opposite side.

**FINAL HARDWARE CHECK:**

Be sure all bolts are torqued to spec. If fuel cell was lowered, check hoses and electrical connections.



Step 23

The closest edge of the exhaust pipe to the MOR/ryde Rubber Spring should be a 2” minimum clearance and 1” minimum clearance to steel components. Other options for exhaust and tailpipe termination may be:

- 1 In front of drive axle,
- 2 behind Frame Hanger or
- 3 out the back of the vehicle.

Be sure when altering exhaust that the joints are gas tight. Acceptable methods may be to weld seams and/or exhaust pipe joint clamps.

**WARNING: The exhaust pipe must not touch or blow on the MOR/ryde rubber spring. Doing so could cause premature failure of the rubber spring.**



Step 24

Perform final check. Be sure all nuts and bolts are properly torqued. Refer to the chart on page 2. Verify spring eye bolt is positioned with bolt head toward the frame.