

# MOR/ryde<sup>®</sup> SERVICE MANUAL

Retain This Manual  
for Future Reference

## T/A MODULAR RUBBER SUSPENSION SYSTEM

### CONTENTS

Section	Subject	Page
I	<b>Description</b> .....	2
II	<b>Maintenance</b> .....	3
	A. Shock Absorber Maintenance .....	3
	B. U-Bolt Maintenance .....	3
III	<b>Service</b> .....	3-4
	A. Procedure for Jacking Up Unit .....	3
	B. Replacement of Rubber Springs .....	3
	C. Replacement of Rubber Bushing .....	3
	D. Replacement of U-Bolts .....	4
	E. Replacement of Shock Absorber .....	4
IV	<b>Specifications</b> .....	5-6
	A. Torque Chart .....	5
	B. Customer Service Information .....	5



Item No.	Description	Item No.	Description
1	Shock Absorber Assembly	11	U-Bolt
2	U-Bolt	12	U-Bolt
3	U-Bolt	13	U-Bolt
4	U-Bolt	14	U-Bolt
5	U-Bolt	15	U-Bolt
6	U-Bolt	16	U-Bolt
7	U-Bolt	17	U-Bolt
8	U-Bolt	18	U-Bolt
9	U-Bolt	19	U-Bolt
10	U-Bolt	20	U-Bolt

## SECTION I

### DESCRIPTION

The MOR/ryde T/A Rubber Suspension System is a unique and technologically advanced suspension. The uniqueness of the MOR/ryde T/A Suspension is in its:

1. Modular Design
2. 100% Natural Rubber Springs
3. Unique Application of Its Trailing Arm

The MOR/ryde T/A Suspension with its rubber springs provides three (3) distinct advantages:

1. Improved Towability and Handling
2. Less Damaging Stress Transmitted to the Towable Vehicle's Body, Components and Contents
3. Ideal for Multi-Axle Applications - Both for RV and Commercial Towable Units

Routine preventive maintenance is critical to insure a MOR/ryde T/A Suspension will provide thousands of safe and trouble-free miles of performance. This Service Manual will provide information regarding routine maintenance and service instructions.

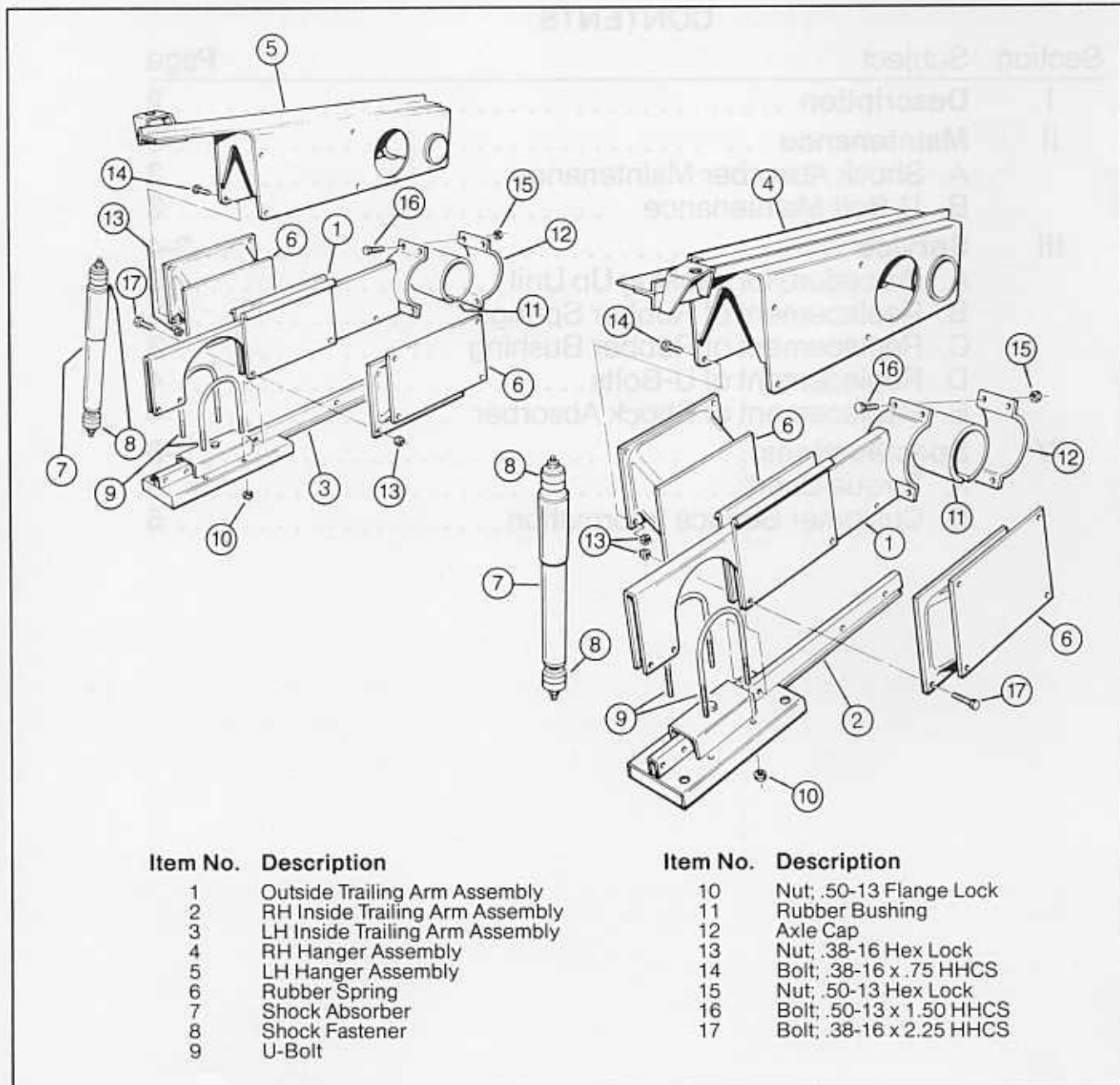

Figure 1 – MOR/ryde T/A Modular Suspension System (Part No. TA1-01)

## SECTION II

### MAINTENANCE

Since the MOR/ryde T/A Axle Suspension requires no lubrication, maintenance is limited to periodic inspections to insure all rubber bushings and rubber springs are intact.

#### II-A. SHOCK ABSORBER MAINTENANCE

The shock absorbers used on the MOR/ryde T/A Suspension are of the sealed, hydraulic type and require no periodic maintenance. Shock absorbers of this type should be checked every 10,000 miles to make sure they are functioning satisfactorily, bushings are not worn, and the dust cover has not been damaged by flying stones or debris from the road. If a shock absorber is leaking, fails to operate, or develops an

unusual noise, the complete unit should be replaced. See Section III-D. for replacement procedure.

#### II-B. U-BOLT MAINTENANCE

In order to insure long-term, safe and trouble-free performance of the MOR/ryde rubber suspension, it is imperative the U-bolt nuts be retorqued at the intervals listed below. This applies to both new vehicles and to vehicles on which U-bolts have been replaced for any reason.

1. The U-bolts must be retorqued after the vehicle has operated under load for 1,000 miles or three (3) months, whichever occurs first.
2. Thereafter, the U-bolt nuts should be checked for proper torque every 5,000 miles or at regular preventive maintenance intervals.

## SECTION III

### SERVICE

#### NOTE:

**ALL SERVICE PROCEDURES MUST BE PERFORMED WITH THE VEHICLE SUPPORTED AT THE FRAME WITH SAFETY STANDS AND THE SUSPENSION HANGING UNSUPPORTED.**

#### III-A. PROCEDURE FOR JACKING UP UNIT

The most efficient location to raise a unit equipped with the MOR/ryde T/A Suspension is either at the main frame of the towable unit or under the U-bolts on the axle attachment to the suspension module. **DO NOT JACK UP ON THE AXLE TUBE.**

#### III-B. REPLACEMENT OF RUBBER SPRINGS

MOR/ryde rubber springs are made of a special formulation of natural rubber. The rubber springs are vulcanized (bonded) to steel plates. There are two (2) unlikely problems that may occur with MOR/ryde rubber springs:

1. The first type is a bond failure. This condition is apparent when the rubber separates from the metal plate.
2. The second type is a rubber failure. This condition is apparent when the rubber tears or delaminates and generally occurs in the middle of the rubber spring between the metal plates.

Either of the conditions described above would not always necessitate replacement of the rubber spring. If there is a question about the integrity of a marginal rubber spring, a 3" wide object (such as a 3" putty knife) can be used to probe the rubber spring in the affected area. If the probe penetrates the crack or separated area .75 inch or more, the spring should be replaced.

(Refer to Figure 2 for following procedure.)

To replace a rubber spring:

1. Make sure the unit is elevated 13-14 inches, the frame is supported with safety stands and the suspension is hanging unsupported.
2. Remove tire from suspension module on which

rubber spring is to be replaced.

3. Disconnect bottom of shock absorber (Item #7).
4. Loosen brake wires to obtain slack.
5. Loosen, but do not remove, .50" bolts attaching axle cap (Item #12) to outside trailing arm assembly (Item #16).
6. Remove .38" bolts (Items #14 and #17) that attach rubber springs to hanger assembly and outside trailing arm assembly.
7. Rotate outside trailing arm assembly (Item #1) down and remove and replace rubber spring (Item #6).
8. Attach rubber springs to outside trailing arm assembly utilizing .38 x 2.25 bolts and nuts (Items #17 and #13).
9. Jack outside trailing arm assembly with rubber springs attached up into hanger assembly until rubber spring bolt holes are aligned and attach with .38 x .75 bolts and nuts (Item #13 and #14).
10. Tighten .50" x 1.50" bolts (Item #16) attaching cap to outside trailing arm assembly. Be sure seam of rubber bushings (Item #11) is pointed down in line with seam of caps.
11. Torque all bolts per Torque Chart in Specification Section.
12. Reattach brake wires to remove slack.
13. Reattach bottom of shock absorber.
14. Reinstall tires and remove jack stands.

#### III-C. REPLACEMENT OF RUBBER BUSHING

(Refer to Figure 2 for following procedure.)

1. Make sure the unit is elevated 13-14 inches, the frame is supported with safety stands and the suspension is hanging unsupported.
2. Remove tire from suspension module on which rubber bushing is to be replaced.
3. Disconnect bottom of shock absorber.
4. Loosen brake wires to obtain slack.
5. Remove .50" x 1.50" bolts (Item #16) attaching cap to outside trailing arm assembly.

## SECTION III

6. Remove .38 x .75 bolts (Item #14) that attach rubber springs to hanger assembly.
7. Rotate outside trailing arm assembly (Item #1) down so clearance is obtained for removal and replacement of rubber bushing (Item #11).
8. Install new rubber bushing (Item #11) making sure seam is pointed down in line with caps.
9. Jack outside trailing arm assembly (Item #1) with rubber springs attached up into hanger assembly until rubber spring bolt holes are aligned and attach with .38" x .75" bolts and nuts (Items #13 and #14).
10. Attach cap (Item #12) to outside trailing arm assembly (Item #1) utilizing .50" x 1.50" bolts. Again, be sure seam of rubber bushing (Item #11) is pointed down in line with seam of caps.
11. Torque all bolts per Torque Chart in Specification Section.
12. Reattach brake wires to remove slack.
13. Reattach bottom of shock absorber.
14. Reinstall tires and remove jack stands.

### III-D. REPLACEMENT OF U-BOLTS

(Refer to Figure 2 for following procedure.)

1. Make sure the unit is elevated 13-14 inches, the frame is supported with safety stands and the suspension is hanging unsupported.
2. Remove U-bolt (Item #9) which is to be replaced.
3. Install new U-bolt.
4. Torque nuts to 70 ft.-lbs.
5. Remove jack stands.

### III-E. REPLACEMENT OF SHOCK ABSORBER

There are four (4) shock absorbers utilized on the MOR/ryde T/A Suspension system. These shock absorbers are made by Monroe with special valving and stroke length specifically designed for the MOR/ryde suspension and are **not** available through any Monroe aftermarket dealers. Consult MOR/ryde, Inc. direct for replacements. Refer to Figure 3.

To replace a shock absorber.

1. Remove fasteners.
2. Remove shock absorber.
3. Install new bushings on new shock absorber per Figure 3.
4. Install new shock absorber.
5. Torque fasteners per Torque Chart in Specification Section.

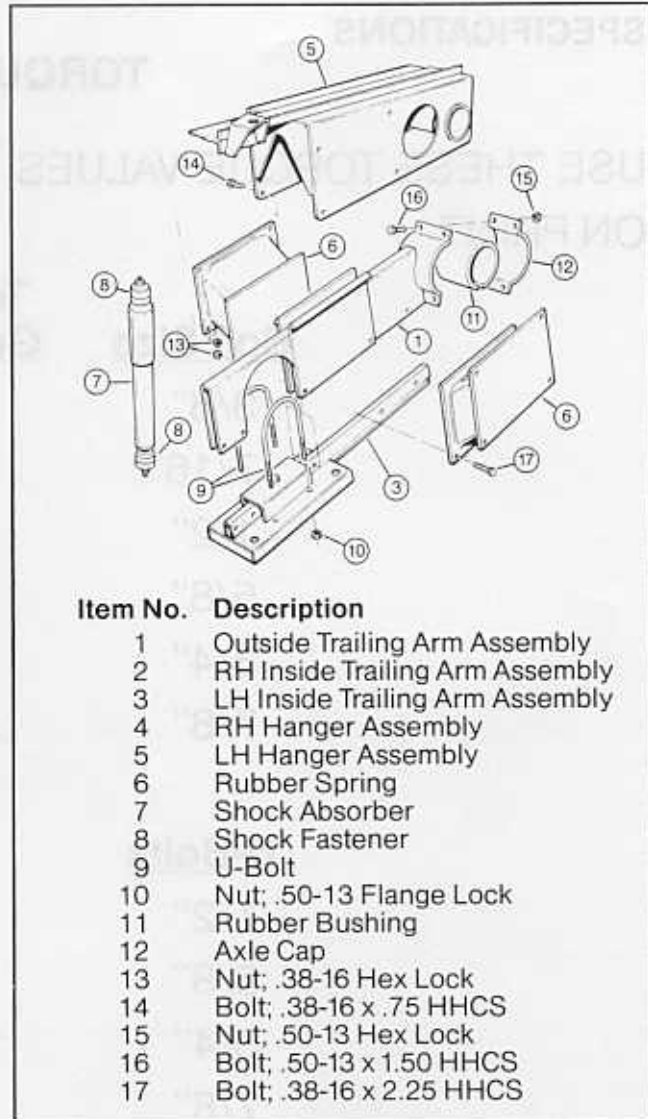

Figure 2 – T/A Module Suspension Explosion

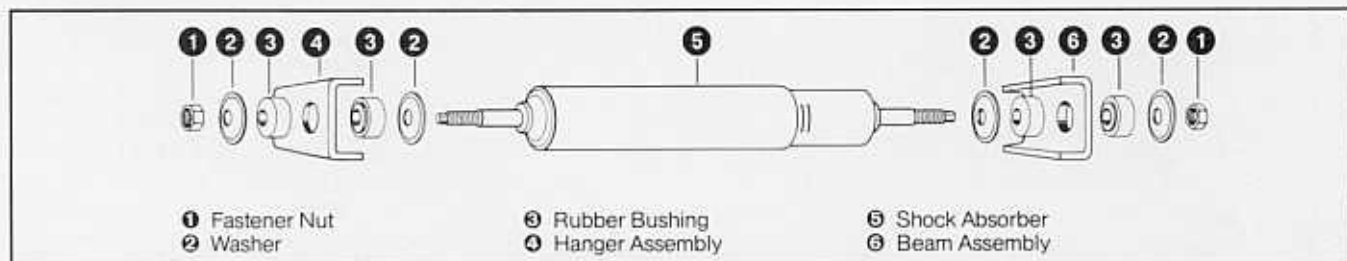

Figure 3 – Shock Absorber and Shock Fasteners

## SECTION IV

### SPECIFICATIONS

### TORQUE CHART

USE THESE TORQUE VALUES UNLESS OTHERWISE SPECIFIED ON PRINT.

<u>Bolt Size</u>	<u>Torque Ft. Lbs.</u>	
	<u>Grade 5</u>	<u>Grade 8</u>
3/8"	24	35
7/16"	30	45
1/2"	45	69
5/8"	90	135
3/4"	150	222
7/8"	227	355
<u>U-Bolts</u>		
1/2"	—	70
5/8"	—	150
3/4"	150	225
7/8"	—	250

**Note:** Torque values must be verified with a torque wrench.  
A calibrated pneumatic impact wrench is not an acceptable substitute.



## MERCHANDISE RETURNS

All goods to be returned to MOR/ryde, Inc. must have a return authorization number assigned prior to their being returned. This will enable MOR/ryde to have better control of parts being returned for replacement or credit.

A return authorization form will be sent out with any parts that are ordered for warranty replacement. In the event that new parts are not sent but there is a need to return parts, please provide MOR/ryde with the proper information before returning the parts. A return authorization form will be mailed to accompany the parts to be returned.

Returned parts, such as rubber springs, are tested in the MOR/ryde laboratory upon their receipt. If, after testing, the parts are determined not to be defective, they will be returned to the customer, freight collect, and credit will not be issued.

All return authorizations will be void after 60 days from the date of issue and the account **will be debited** accordingly.

## CUSTOMER SERVICE

If you have any questions about servicing the MOR/ryde Rubber Suspension system or wish to order parts, please call the MOR/ryde Customer Service Department. You may telephone (574) 293-1581 between 8:00 a.m. to 4:30 p.m. EST, Monday through Friday.