



SMART/ryde Service Manual

SUSPENSION SYSTEM: A01-07, -08, -09, -10, -12

CONTENTS

<u>SECTION</u>	<u>SUBJECT</u>	<u>PAGE</u>
I	Description	1
II	Maintenance	6
	A. Shock Absorber	6
	B. Fastener Maintenance	6
III	Service	6
	A. Replacement of Rubber Bushing	6
	B. Replacement of Shock Absorber	7
	C. Replacement of Rubber Springs	8
	D. Replacement of Crossmember	8
	E. U-Bolt Replacement	9
	F. Beam Assembly Replacement	10
IV	Torque Requirements	11

SECTION I

Description

The SMART/ryde is an add-on axle suspension system that utilizes MOR/ryde's unique rubber springs. The primary features of SMART/ryde are:

1. Use of triple rubber spring assemblies.
2. Position of rubber spring assemblies.
3. Maintains chassis suspension system, D dimension and driveline specifications.
4. Side to side adjustability to compensate for cross vehicle loading.
5. Specially valved shock absorbers.

The SMART/ryde suspension system provides:

1. A smooth ride.
2. Much improved handling.
3. Greater roll stability.

This service manual will provide information regarding routine maintenance and service instructions.

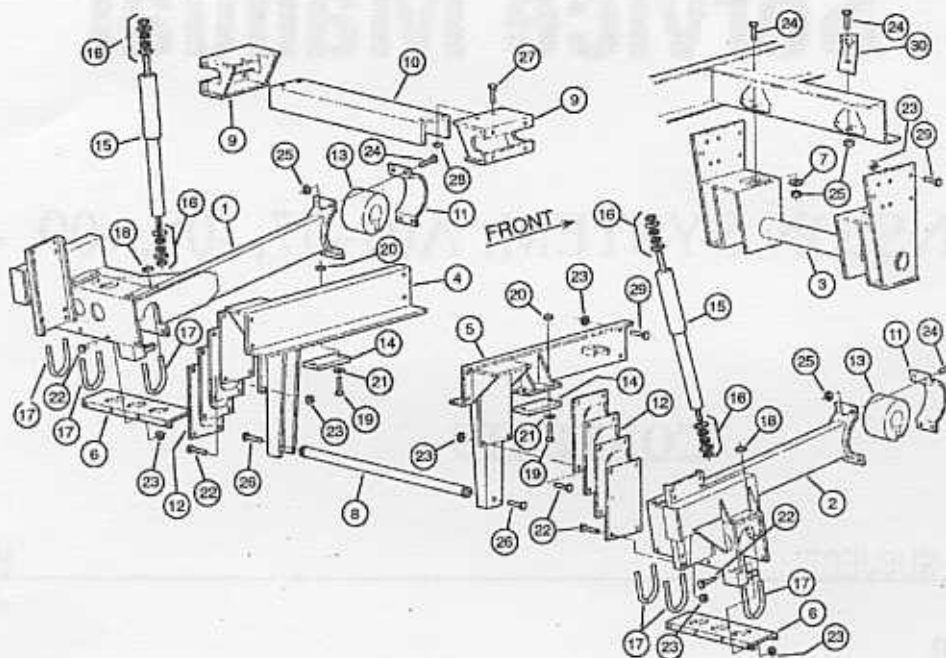

Figure 1: SMART/ryde Tag Axle Suspension System (Part Nos. A01-02, A01-04, A01-07, A01-07-A, A01-09, A01-09-A) Chevrolet P30

<u>Item No.</u>	<u>Description</u>	<u>Item No.</u>	<u>Description</u>	<u>Item No.</u>	<u>Description</u>
1	Beam Assembly LH	11	Beam Cap	21	Washer; .25 ID
2	Beam Assembly RH	12	Rubber Spring Assembly	22	Bolt; .38-16 x .88 HHCB GR5
3	Front Hanger Assembly	13	Rubber Bushing	23	Nut; .38-16 Hex LK
4	Rear Hanger Assembly LH	14	Rubber Bumper Stop	24	Bolt; .50-13 x 1.50 HHCB GR5
5	Rear Hanger Assembly RH	15	Shock Absorber	25	Nut; .50-13 Hex LK
6	Bottom Beam Insert	16	Shock Fastener	26	Bolt; .75-10 x 2 HHCB GR5
7	Washer; .50 ID	17	U-bolt; .63-18 x 1.75	27	Bolt; .75-10 x 1.5 HHCB GR5
8	Cross Member Tube	18	Nut; .63-18 Hex Flange	28	Nut; .75-10 Hex
9	Cross Member End	19	Bolt; .25-20 x 1.5 HHCB GR5	29	Bolt; .38-16 x 1.25 HHCB GR5
10	Cross Member	20	Nut; 25-20 Hex LK	30	Brake Line Retainer

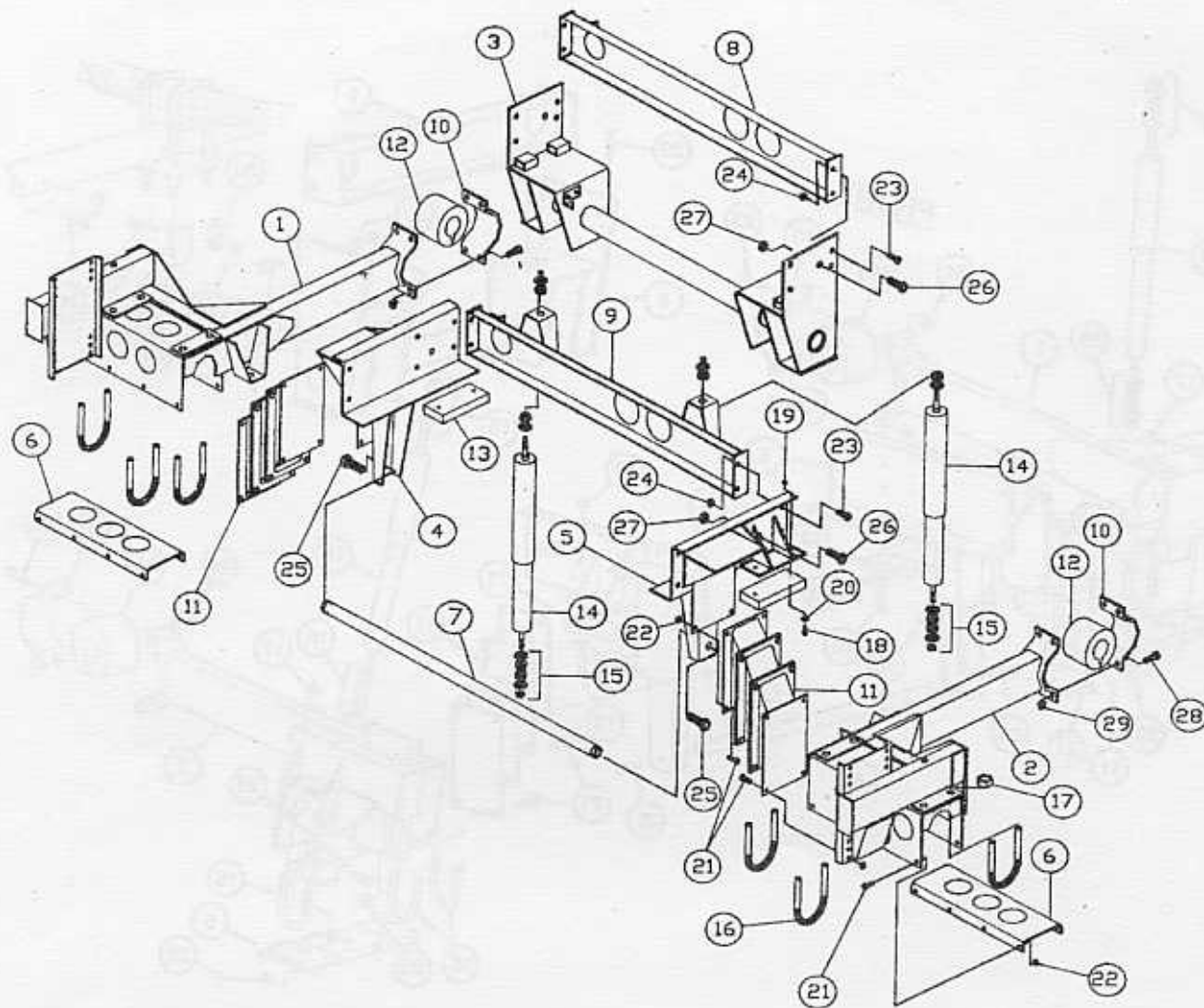

Figure 2: SMART/ryde Tag Axle Suspension System (Part Nos. A01-06, A01-12, A01-12-A, A01-15, A01-16) Ford E-350

<u>Item No.</u>	<u>Description</u>	<u>Item No.</u>	<u>Description</u>	<u>Item No.</u>	<u>Description</u>
1	Beam Assembly LH	13	Rubber Bumper Stop	25	Bolt; .75-10 x 2 HHCB GR5
2	Beam Assembly RH	14	Shock Absorber	26	Bolt; .63-11 x 2 HFCB GR 8
3	Front Hanger Assembly	15	Shock Fastener	27	Nut; .63-11 FL LK
4	Rear Hanger Assembly LH	16	U-bolt; .63-18 x 1.75	28	Bolt; .50-130 x 1.5 HHCB GR 5
5	Rear Hanger Assembly RH	17	.63-18 FL HD U-bolt Nut	29	Nut; .5-13 HEX LK
6	Bottom Beam Insert	18	Bolt; .25-20 x 1.5 HHCB GR 5		
7	Cross Memeber Tube	19	Nut; .25-20 HEX LK		
8	Front Cross-Member	20	Washer; .25 ID		
9	Rear Cross Memeber	21	Bolt; .38-16 x .88 HHCB GR5		
10	Beam Cap	22	Nut; .38-16 Hex LK		
11	Rubber Spring Assembly	23	Bolt; .44-14 x 1.5 HCFB		
12	Rubber Bushing	24	Nut; 4-14 FL LK		

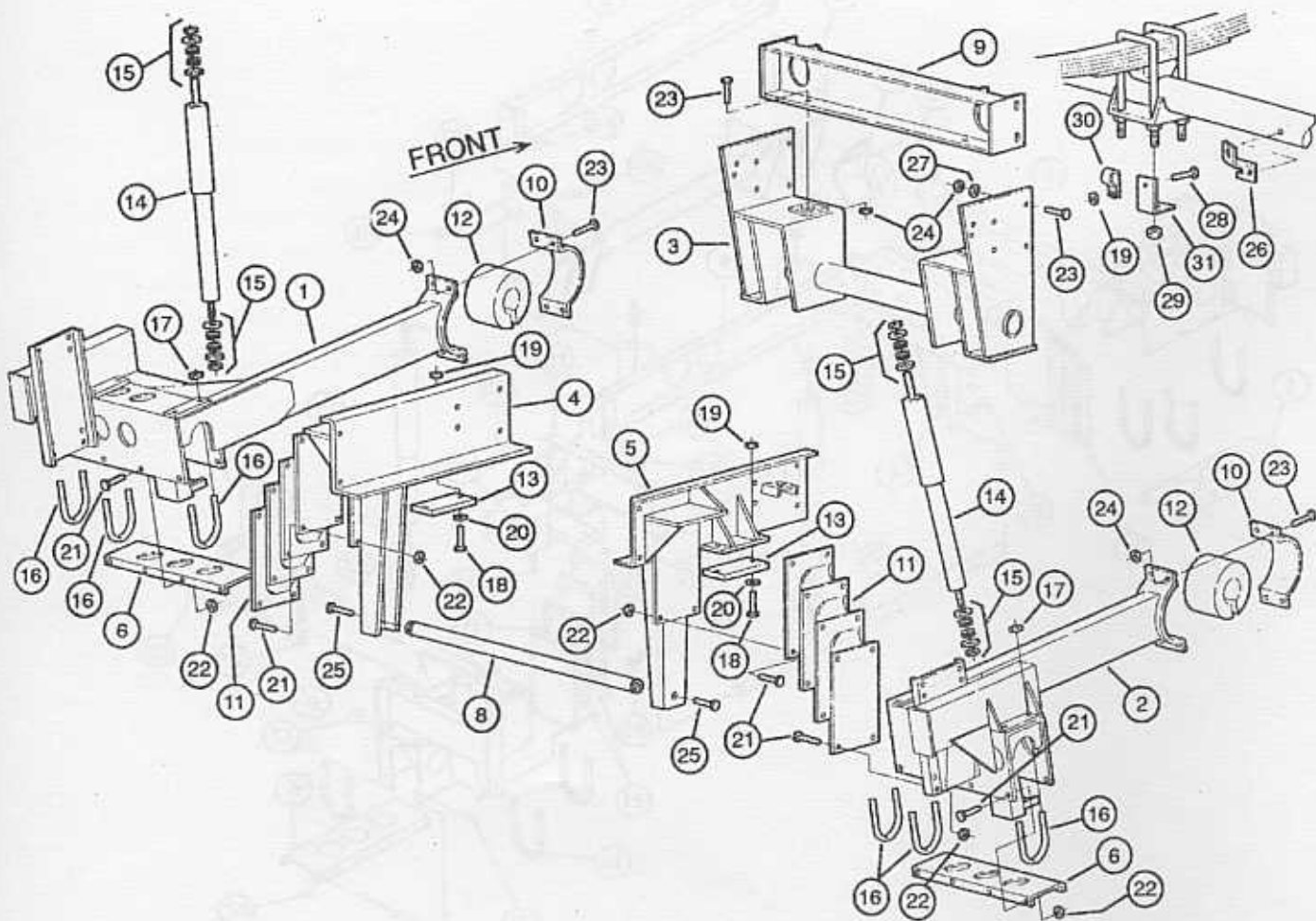

Figure 3 : SMART/ryde Tag Axle Suspension System (Part Nos. A01-03, A01-08, A01-08-A) Ford F53

<u>Item No.</u>	<u>Description</u>	<u>Item No.</u>	<u>Description</u>	<u>Item No.</u>	<u>Description</u>
1	Beam Assembly LH	14	Shock Absorber	26	Brake Line Bracket
2	Beam Assembly RH	15	Shock Fastener	27	Washer; .5 ID
3	Front Hanger Assembly	16	U-bolt; .63-18 x 1.75	28	Bolt; .25-20 x 1.0 HHCB GR2
4	Rear Hanger Assembly LH	17	Nut; .63-18 Hex Flange	29	Nut; .75-16 FH-No Lock
5	Rear Hanger Assembly RH	18	Bolt; .25-20 x 1.5 HHCB GR5	30	Coated Loop Clamp
6	Bottom Beam Insert	19	Nut; 25-20 Hex LK	31	Brake Line Brace
8	Cross Member Assembly	20	Washer; .25 ID		
9	Cross Member	21	Bolt; .38-16 x .88 HHCB GR5		
10	Beam Cap	22	Nut; .38-16 Hex LK		
11	Rubber Spring Assembly	23	Bolt; .50-13 x 1.50 HHCB GR5		
12	Rubber Bushing	24	Nut; .50-13 Hex LK		
13	Rubber Bumper Stop	25	Bolt; .75-10 x 2 HHCB GR5		

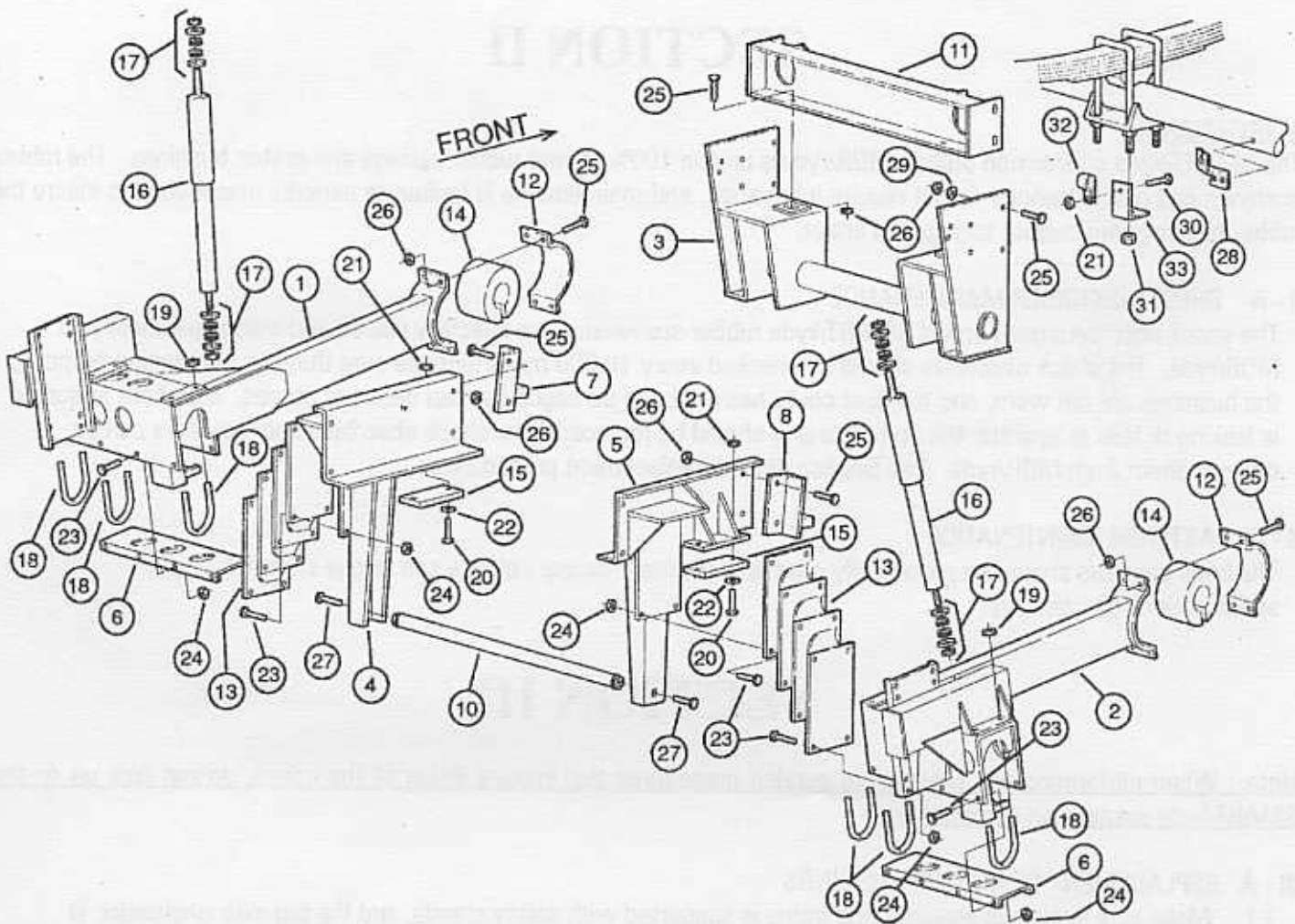

Figure 4 : SMART/ryde Tag Axle Suspension System (Part Nos. A01-05, A01-10, A01-10-A) Ford F53

<u>Item No.</u>	<u>Description</u>	<u>Item No.</u>	<u>Description</u>	<u>Item No.</u>	<u>Description</u>
1	Beam Assembly LH	13	Rubber Spring Assembly	24	Nut; .38-16 Hex LK
2	Beam Assembly RH	14	Rubber Bushing	25	Bolt; .50-13 x 1.5 HHCB GR5
3	Front Hanger Assembly	15	Rubber Bumper Stop	26	Nut; .50-13 Hex LK
4	Rear Hanger Assembly LH	16	Shock Absorber	27	Bolt; .75-10 x 2 HHCB GR5
5	Rear Hanger Assembly RH	17	Shock Fastner	28	Brake Line Bracket
6	Bottom Beam Insert	18	U-bolt; .63-18 x 1.75	29	Washer; .5 ID
7	Shock Mount LH	19	Nut; .63-18 Hex Flange	30	Bolt; .25-20 x 1.0 HHCB GR2
8	Shock Mount RH	20	Bolt; .25-20 x 1.5 HHCB GR5	31	Nut; .75-16 FH-No Lock
10	Cross Member Tube	21	Nut; .25-20 Hex LK	32	Coated Loop Clamp
11	Cross Member	22	Washer; .25 ID	33	Brake Line Brace
12	Beam Cap	23	Bolt; .38-16 x .88 HHCB GR5		

SECTION II

MAINTENANCE

The SMART/ryde suspension utilizes MOR/ryde's unique 100% natural rubber springs and rubber bushings. The rubber bushings and rubber springs do not require lubrication, and maintenance is limited to periodic inspections to insure the rubber bushings and rubber springs are intact.

II - A SHOCK ABSORBER MAINTENANCE

The shock absorbers used on the SMART/ryde rubber suspension are specially valved and made specifically for MOR/ryde. The shock absorbers should be checked every 10,000 miles to make sure they are functioning properly, the bushings are not worn, and the dust cover has not been damaged by road debris or stones. If a shock absorber is leaking or fails to operate, the complete unit should be replaced. The shock absorbers and fasteners can be ordered direct from MOR/ryde. See Section III-B for replacement procedures.

II - B FASTENER MAINTENANCE

The bolts and nuts should be periodically checked for proper torque - please see torque chart for proper specifications (Section IV).

SECTION III

Note : When performing the subsequent service procedures that require lifting of the coach, do not jack up on the SMART/ryde suspension components.

III - A REPLACEMENT OF RUBBER BUSHINGS

- 1.) Make sure vehicle is elevated, the frame is supported with safety stands, and the tag axle suspension is hanging unsupported.
- 2.) Support tag axle with floor jack and safety stands.
- 3.) Remove 1/2" bolts from beam assembly and end caps (See Figure 5).
- 4.) Remove end caps, move beam assemblies rearward to reveal bushings.
- 5.) Remove rubber bushings from journals.
- 6.) Install new rubber bushings. Note: bushings must be positioned with the seam pointed downward (See Figure 5).
- 7.) Reposition beam assemblies and end caps.
- 8.) Insert new 1/2" bolts. Torque to proper specifications.
- 9.) Remove floor jacks and safety stands.

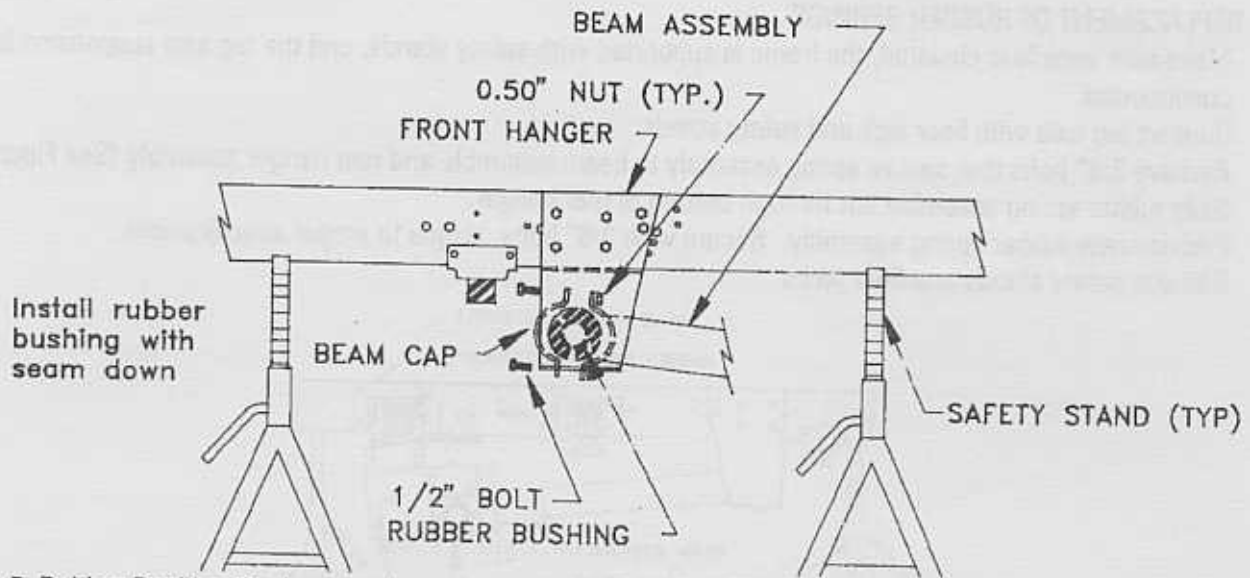

Figure 5: Rubber Bushing Replacement

III - B REPLACEMENT OF TAG AXLE SHOCK ABSORBERS

- 1.) Remove shock fasteners and rubber bushings shown in Figure 6.
- 2.) Compress shock absorber to clear mounts. Remove shock absorber.
- 3.) Install new bushings on new shock absorber.
- 4.) Install new shock absorber.
- 5.) Torque fasteners per torque chart.

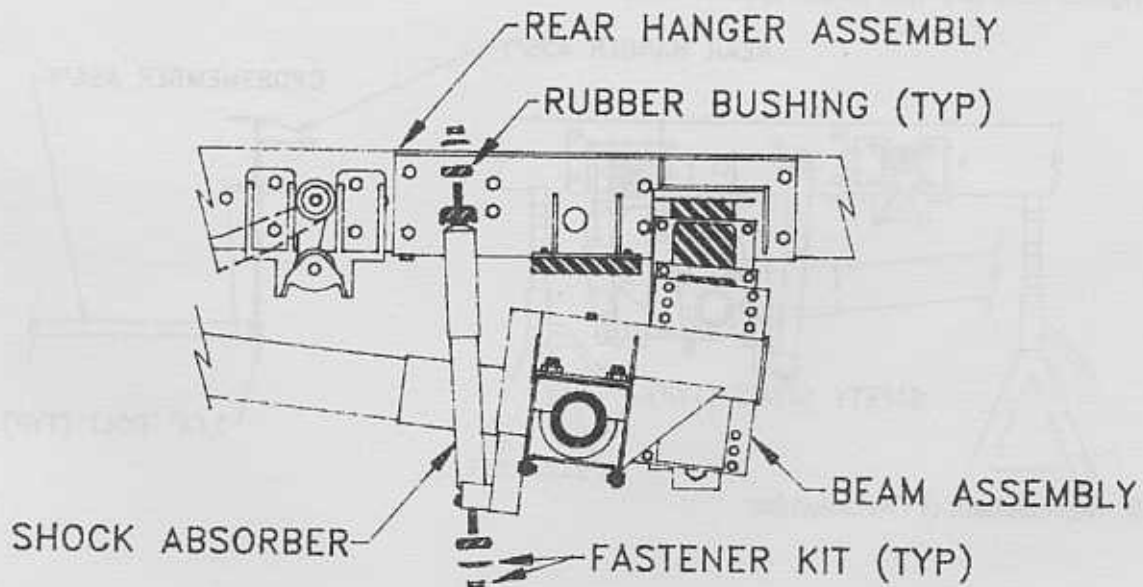

Figure 6: Replacement of Shock Absorber

III - C REPLACEMENT OF RUBBER SPRINGS

- 1.) Make sure vehicle is elevated, the frame is supported with safety stands, and the tag axle suspension is hanging unsupported.
- 2.) Support tag axle with floor jack and safety stands.
- 3.) Remove 3/8" bolts that secure spring assembly to beam assembly and rear hanger assembly (See Figure 7).
- 4.) Slide rubber spring assembly out through bottom of rear hanger.
- 5.) Position new rubber spring assembly. Secure with 3/8" bolts, torque to proper specifications.
- 6.) Remove safety stands and floor jacks.

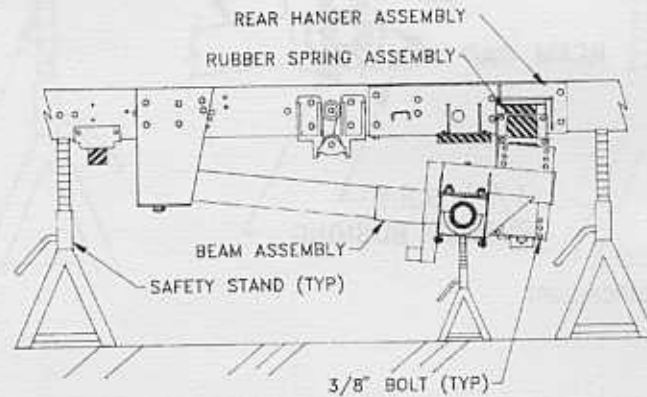

Figure 7: Replacement of Rubber Spring

III - D REPLACEMENT OF CROSSMEMBER

- 1.) Remove 3/4" bolts securing crossmember assembly (See Figure 8). Remove crossmember.
- 2.) Install new crossmember. Secure with 3/4" bolts.
- 3.) Tighten bolts to proper torque specifications.

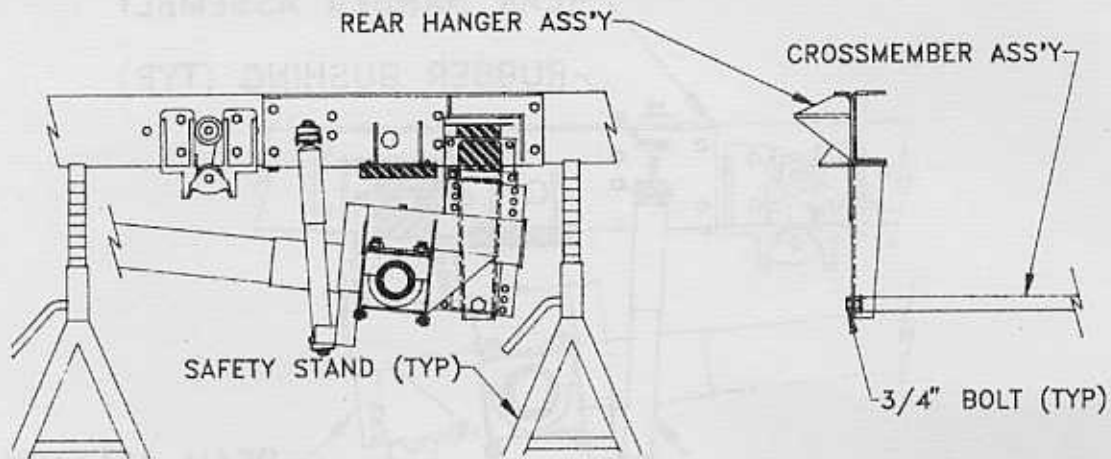

Figure 8: Replacement of Crossmember

III - E U-BOLT REPLACEMENT

- 1.) Make sure vehicle is elevated, the frame is supported with safety stands, and the tag axle suspension is hanging unsupported.
- 2.) Support tag axle with floor jack and safety stands.
- 3.) Remove 3/8" bolts (eight (8) per beam assembly) from beam assembly and bottom beam insert (See Figure 9).
- 4.) Dislocate bottom beam insert.
- 5.) Remove 5/8" U-bolt nuts from U-bolt. Remove U-bolt through bottom of beam assembly.
- 6.) Install new U-bolt. Secure with 5/8" U-bolt nuts. Torque to proper specifications.
- 7.) Repeat steps 5 and 6 for all U-bolts that must be replaced, there are three (3) U-bolts per beam assembly.
- 8.) Insert bottom beam insert. Secure with 3/8" bolts.
- 9.) Torque all bolts to proper specifications.
- 10.) Remove safety stands and floor jacks.

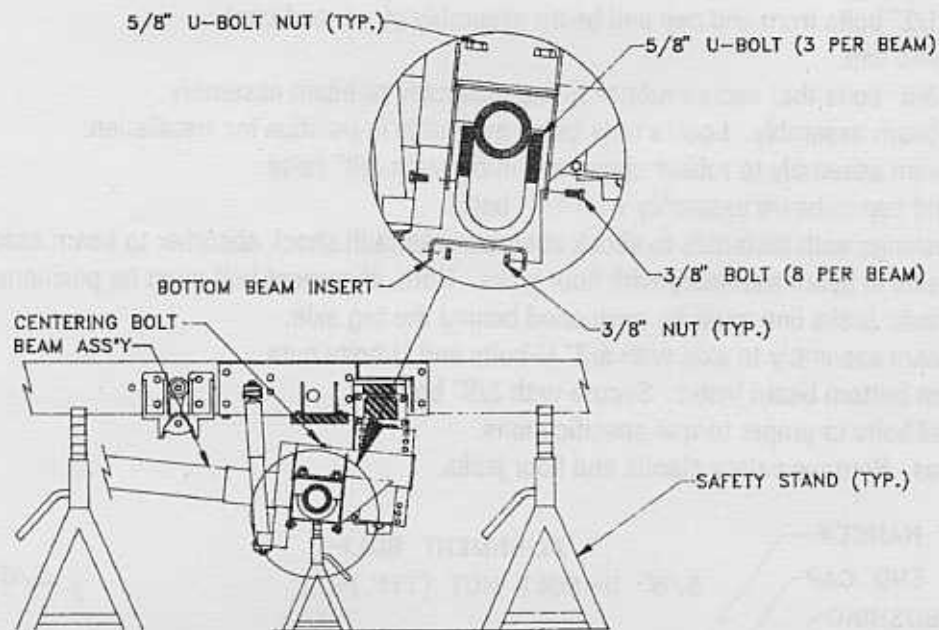

Figure 9: U-Bolt Replacement

III - F BEAM ASSEMBLY REPLACEMENT

- 1.) Make sure vehicle is elevated, the frame is supported with safety stands and the tag axle suspension is hanging unsupported.
- 2.) Support tag axle with floor jack and safety stands.
- 3.) Remove tires from tag axle.
- 4.) Remove 3/8" bolts (eight (8) per beam assembly) from beam assembly and bottom beam insert (See Figures 9 and 10).
- 5.) Dislodge bottom beam insert.
- 6.) Remove 5/8" U-bolt nuts from U-bolt. Remove U-bolt through bottom of beam assembly.
- 7.) Support beam assembly with safety stands.
- 8.) Lower tag axle from beam assemblies with floor jacks.
- 9.) Remove shock fasteners and rubber bushings at bottom of shock absorber (See Figure 6). Compress shock absorber to clear lower mount.
- 10.) Remove 1/2" bolts from end cap and beam assembly (4 per end cap).
- 11.) Remove end cap.
- 12.) Remove 3/8" bolts that secure rubber spring assembly to beam assembly.
- 13.) Remove beam assembly. Locate new beam assembly in position for installation.
- 14.) Attach beam assembly to rubber spring assembly with 3/8" bolts.
- 15.) Attach end cap to beam assembly with 1/2" bolts.
- 16.) Install bushings with fasteners to shock absorber, reattach shock absorber to beam assembly.
- 17.) Position axle in beam assembly with floor jacks. Note, alignment bolt must be positioned correctly in axle seat. The hydraulic brake line must be positioned behind the tag axle.
- 18.) Attach beam assembly to axle with 5/8" U-bolts and U-bolts nuts.
- 19.) Reposition bottom beam insert. Secure with 3/8" bolts.
- 20.) Tighten all bolts to proper torque specifications.
- 21.) Install tires. Remove safety stands and floor jacks.

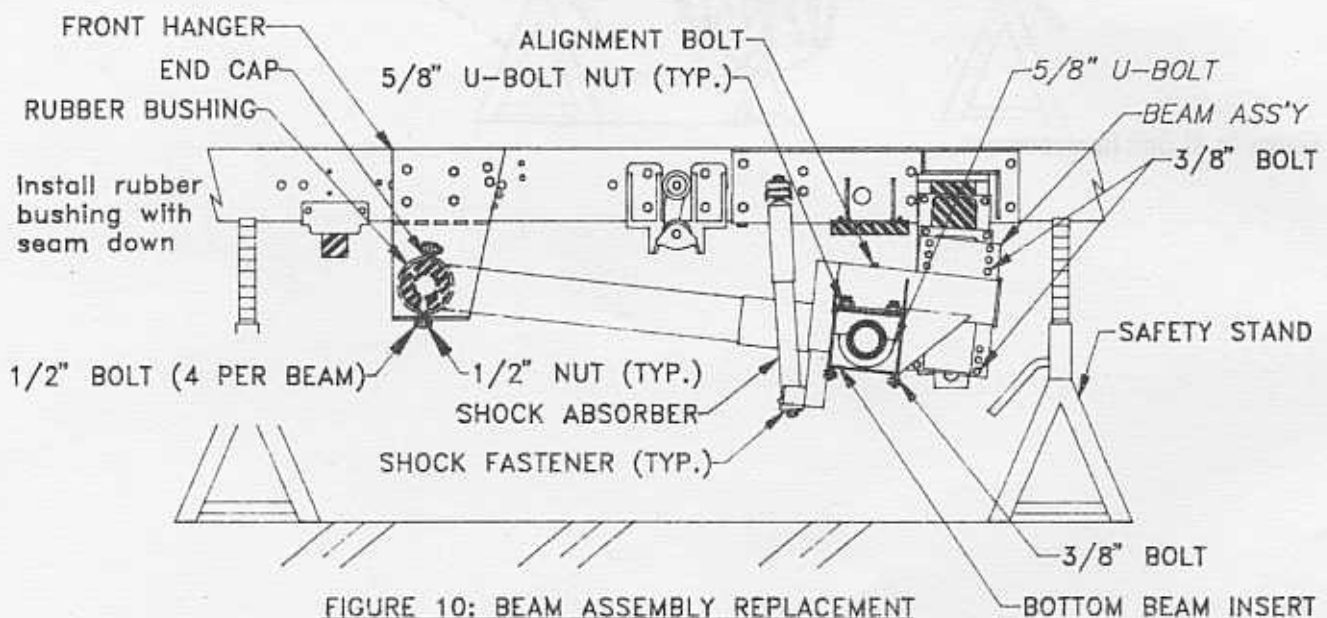

FIGURE 10: BEAM ASSEMBLY REPLACEMENT

Figure 10: Beam Assembly Replacement

SECTION IV

Torque Requirements

The following table provides the torque requirements for bolts used on the SMART/ryde.

Bolt Size	Grade 5	Grade 8
.25-20	7	10
.38 - 16	24	30
.44 - 14	38	45
.50 - 13	50	68
.63 - 11	95	115
.75 - 10	60	
U-Bolt		
.63 - 18		150
.75 - 16		250
.88 - 14		500

Use above torque values unless otherwise specified on installation print

Note: Torque value must be verified with a torque wrench. A calibrated pneumatic impact wrench is not an acceptable substitute.