

Retain This Manual  
for Future Reference

## RUBBER SUSPENSION SYSTEM

**Chassis Codes:** M07-15 (Navistar International), M07-19 (Ford),  
M07-20 (Ford), M07-33, M07-42 (Chevrolet/GM),  
M07-43 (Blue Bird TC-2000)

### CONTENTS

Section	Subject	Page
I	<b>Description</b> .....	2
II	<b>Maintenance</b> .....	3
	A. U-Bolt Maintenance .....	3
	B. Shock Absorber Maintenance .....	3
III	<b>Service</b> .....	3-6
	A. Replacement of U-bolts, Leveling Bolt, or Axle Pad - Adjustment Seat .....	3
	B. Replacement of Rubber Springs .....	3,4
	C. Replacement of Cross-Member Straps .....	4
	D. Replacement of Trac Bar Bushings .....	4,5
	E. Replacement of Beam Assembly .....	5
	F. Replacement of Hanger Assembly .....	6
	G. Replacement of Shock Absorber .....	6
IV	<b>Specifications</b> .....	6-8
	A. Rubber Springs .....	6,7
	B. Torque Values .....	7
	C. Trac Bar Adjustment .....	8

# SECTION I

## DESCRIPTION

The MOR/ryde rubber suspension system is a unique and technologically advanced suspension. The uniqueness of the MOR/ryde suspension is in its:

1. 100% Natural Rubber Springs
2. 13-inch Wider Spring Center
3. Frame Attachment, Fore and Aft the Drive Wheels Without a Slip Joint
4. Side-to-Side Adjustability to Compensate for Unequal Cross-Vehicle Loading

The MOR/ryde suspension system with its rubber

springs provides three (3) distinct advantages:

1. Improved Passenger Comfort
2. Improved Safety Through Greater Driver Control
3. Reduced Maintenance and Operational Costs

Routine preventive maintenance is critical to insure a MOR/ryde suspension will provide thousands of safe and trouble-free miles of performance on a school bus chassis. This Service Manual will provide information regarding routine maintenance and service instructions.

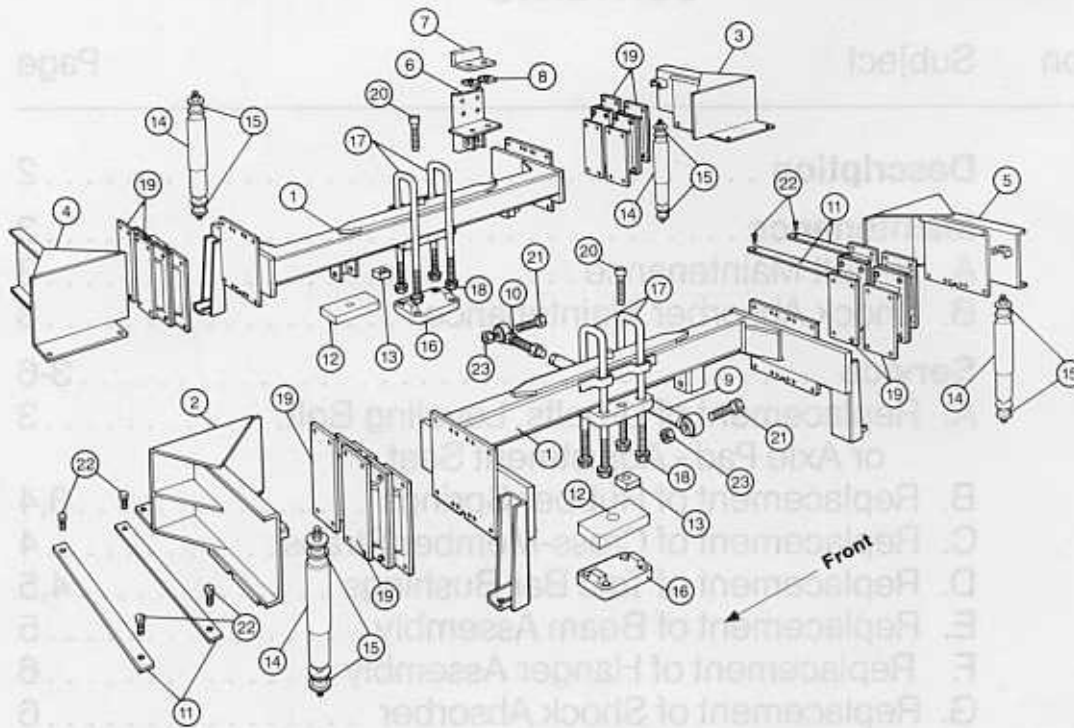

Item No.	Description	Item No.	Description
1	Beam Assembly	13	Axle Pad - Adjustment Seat
2	Hanger Assembly, LF	14	Shock Absorber
3	Hanger Assembly, RR	15	Shock Fastener
4	Hanger Assembly, RF	16	Bottom U-bolt Casting
5	Hanger Assembly, LR	17	U-bolt
6	Frame Sway Bracket	18	U-bolt Nut
7	Sway Bracket - Inside Flange Brace	19	Rubber Spring Assembly
8	Spacer, .25 x 1.0 x 1.0	20	Bolt, .75-10 x 3.50 Allen Head
9	Trac Bar Assembly	21	Bolt, .75-10 x 3.60 HHCS
10	Trac Bar Adjustment w/Nut	22	Bolt, .50-13 x 1.75 FH GD 8
11	Cross Member Strap	23	Nut, .75-10 Hex Lock
12	Axle Pad Assembly		

Figure 1 – MOR/ryde Rubber Suspension System (School Bus Chassis)

## SECTION II

### MAINTENANCE

#### NOTE:

**ALL MAINTENANCE PROCEDURES MUST BE PERFORMED WITH THE VEHICLE SUPPORTED AT THE FRAME WITH SAFETY STANDS, THE FRONT WHEELS BLOCKED, AND THE SUSPENSION HANGING UNSUPPORTED.**

Since the MOR/ryde Rubber Suspension requires no lubrication, maintenance is limited to periodic inspections to insure specified torque values are maintained (see Torque Chart in Specification Section) and leveling bolts and pads are in place and tight. If leveling bolts and axle pad-adjustment seat are loose or missing, refer to Section III-A, "Replacement of U-Bolts, Leveling Bolt or Axle Pad-Adjustment Seat," for proper procedure.

#### II-A. U-BOLT MAINTENANCE

In order to insure long-term, safe, and trouble-free performance of the MOR/ryde Rubber Suspension, it is imperative that the U-bolt nuts be retorqued at the intervals listed below. This applies to both new vehicles and to vehicles on which U-bolts have been replaced for any reason.

1. The U-bolts must be retorqued after the vehicle has operated **under load** for 1,000 miles or three (3) months, whichever occurs first.
2. Thereafter, the U-bolt nuts should be checked for

proper torque every 5,000 miles or at regular preventive maintenance intervals.

During all U-bolt torquing procedures, utilize the torque sequence shown in Figure 2.

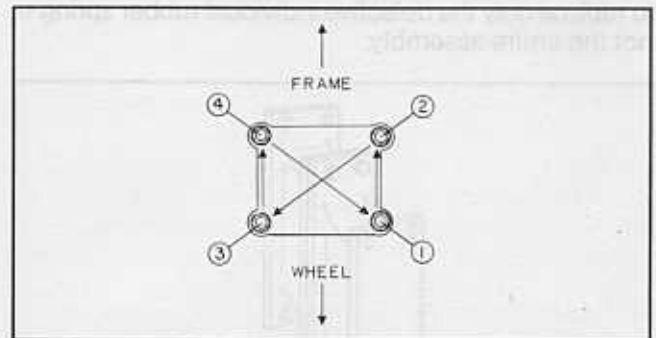

Figure 2 — U-bolt Torque Sequence

#### II-B. SHOCK ABSORBER MAINTENANCE

The shock absorbers used on the MOR/ryde Rubber Suspension are of the sealed, hydraulic type and require no periodic maintenance. Shock absorbers of this type should be checked every 10,000 miles to make sure they are functioning satisfactorily, bushings are not worn, and the dust cover has not been damaged by flying stones or debris from the road. If a shock absorber is leaking, fails to operate, or develops an unusual noise, the complete unit should be replaced. See Section III-G for replacement procedure.

## SECTION III

### SERVICE

#### III-A. REPLACEMENT OF U-BOLTS, LEVELING BOLT, OR AXLE PAD-ADJUSTMENT SEAT

1. Make sure vehicle is elevated and chassis is supported with safety stands, the front wheels blocked, and the suspension hanging unsupported.
2. Tighten U-bolt nuts to 50 ft.-lbs. of initial torque.
3. Tighten leveling bolt on side of beam assembly into axle pad-adjustment seat that sits on top of axle. Torque to 75 ft. lbs.
4. Tighten U-bolt nuts utilizing the torque sequence until 250 ft.-lbs. of final torque is achieved. Refer to Figure 2.

**NOTE: Torque values must be verified with a torque wrench. A calibrated pneumatic impact wrench is NOT an acceptable substitute.**

#### III-B. REPLACEMENT OF RUBBER SPRINGS

MOR/ryde Rubber Springs are made of a special

formulation of natural rubber. The rubber springs are vulcanized (bonded) to steel plates. There are two (2) unlikely problems that may occur with MOR/ryde rubber springs:

1. The first type is a bond failure. This condition is apparent when the rubber separates from the metal plate.
2. The second type is a rubber failure that is due to a compounding problem during the manufacturing process. This condition is apparent when the rubber tears or delaminates and generally occurs in the middle of the rubber spring between the metal plates.

Either of the conditions described above would not always necessitate replacement of the rubber spring. If there is a question about the integrity of a marginal rubber spring, a 3" wide object (such as a 3" putty knife) can be used to probe the rubber spring in the affected area. If the probe penetrates the crack or separated area .75 inch or more, the spring should be replaced.

## SECTION III

### REMEMBER:

The rubber spring assembly is actually two (2) individual rubber springs with the 5.0 x 11.0 or 6.50 x 11.0 steel plates bolted back-to-back (Figure 3). If only one spring in the assembly is defective, it is necessary to replace only the defective individual rubber spring—not the entire assembly.

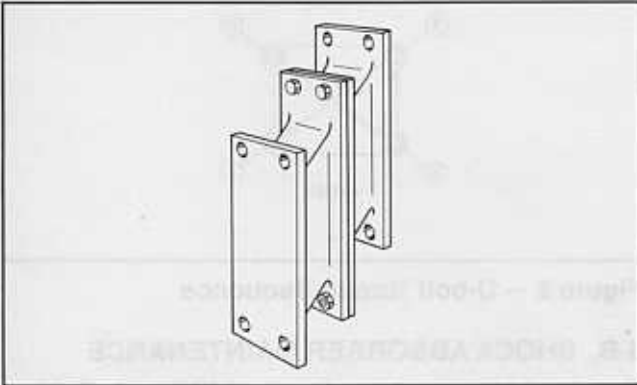

Figure 3 — Rubber Spring Assembly

To replace a rubber spring:

1. Make sure vehicle is elevated and chassis is supported with safety stands, the front wheels blocked, and the suspension hanging unsupported.
2. Remove 3/8" bolts securing the rubber spring assembly to beam assembly and to frame hanger assembly.
3. Rubber spring assembly can now be removed by pulling downward and out. (Spring assembly **cannot** be removed by forcing upward.)
4. Install new spring assembly by pushing spring assembly upward (either by hand or with jack) between the beam assembly and frame hanger assemblies until the bolt holes are aligned (Figure 4). Secure spring assembly with 3/8" x 7/8" Grade 8 bolts. Torque bolts per torque chart in Specification Section.

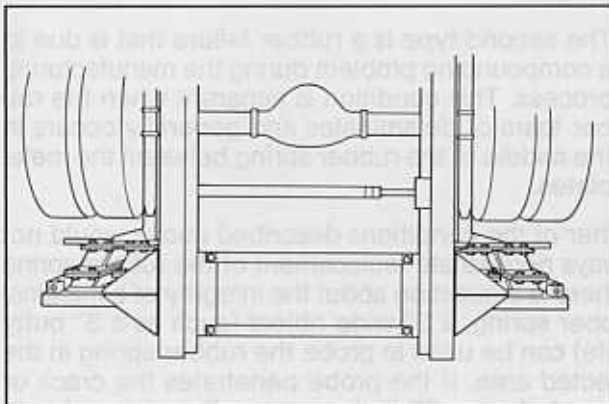

Figure 5 - Cross Member Straps

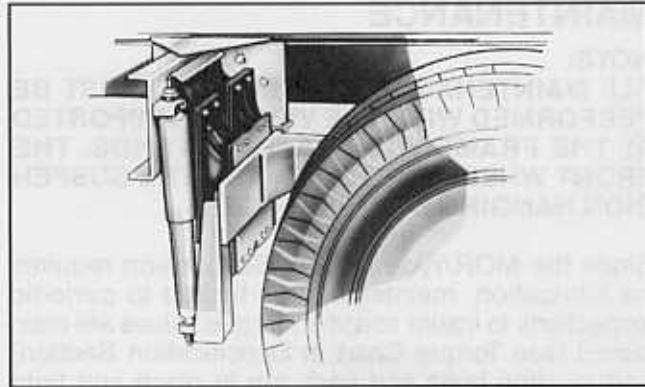

Figure 4 - Rubber Spring Assembly and Hanger Assembly

### III-C. REPLACEMENT OF CROSS-MEMBER STRAPS

The cross-member straps (Figure 5) utilized on the MOR/ryde Suspension are very critical parts in assuring the integrity of the suspension system. The purpose of these cross-member straps is to keep the bottoms of the MOR/ryde hangers from spreading apart. Failure to repair broken or loose cross-member straps will **always** result in the fracture of the MOR/ryde hanger assembly and/or the chassis side-members. Most cross-member strap failures are due to the 1/2" attaching bolts not being properly torqued.

To replace a cross-member strap:

1. Make sure vehicle is elevated and chassis is supported with safety stands, the front wheels blocked, and the suspension hanging unsupported.
2. Remove defective cross-member strap.
3. Install new cross-member strap.
4. Torque bolts per Torque Chart in Specification Section.

### III-D. REPLACEMENT OF TRAC BAR BUSHINGS

The MOR/ryde Suspension utilizes a trac bar, Figure 6.

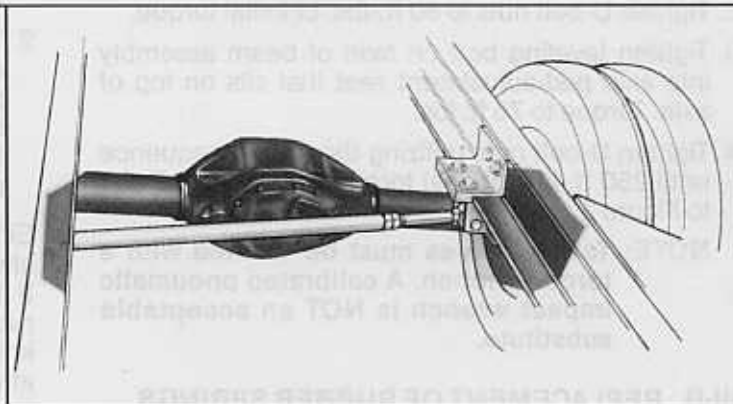
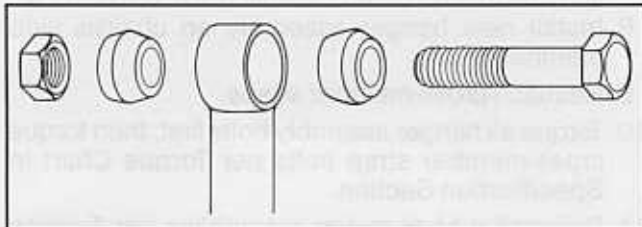

Figure 6 - Trac Bar Assembly/Adjustment w/Nut

## SECTION III

Its purpose is to keep the drive wheels parallel with the center line of the vehicle which minimizes lateral instability and provides improved handling. There have been three different designs of trac bars used. The original design was used through January, 1982, after which the design was changed. Refer to Figures 7, 8, and 9.



**Figure 7 — Trac Bar Bushings  
(Used Prior to February, 1982)**

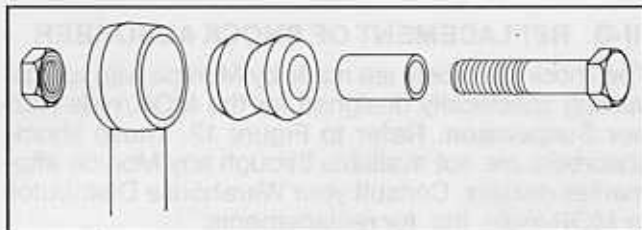

**Figure 8 — Trac Bar Bushings  
(Used from February, 1982 to February, 1988.)**

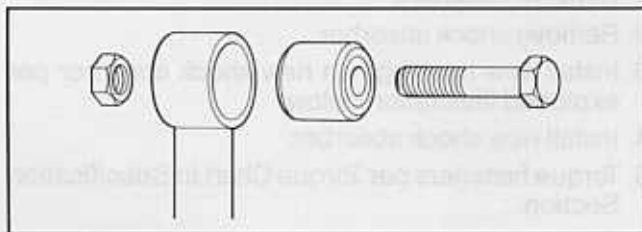

**Figure 9 — Trac Bar Bushings  
(Used from March, 1988 to Present.)**

To replace bushings in trac bar assembly:

1. Remove 3/4" bolts from either end of trac bar.
2. Remove trac bar.
3. Replace bushings.
4. Reinstall trac bar.
5. Torque 3/4" bolts per Torque Chart in Specification Section.

### III-E. REPLACEMENT OF BEAM ASSEMBLY

The beam assembly utilized on the MOR/ryde Rubber Suspension supports one side of the rubber springs forward and rearward of axle, the bottom of the shock absorbers, and is located on the axle in the same position the steel leaf springs would have been. There have been two (2) different designs of beam assemblies used. The original design was used through September, 1986, after which the design was changed and is still current. The new design will completely interchange

with the older design with no modification necessary. Refer to Figures 10 and 11. The beam assembly is attached to the axle through U-bolts. The proper torquing procedure in attaching the beam assembly to the axle is **extremely** important to suspension reliability.

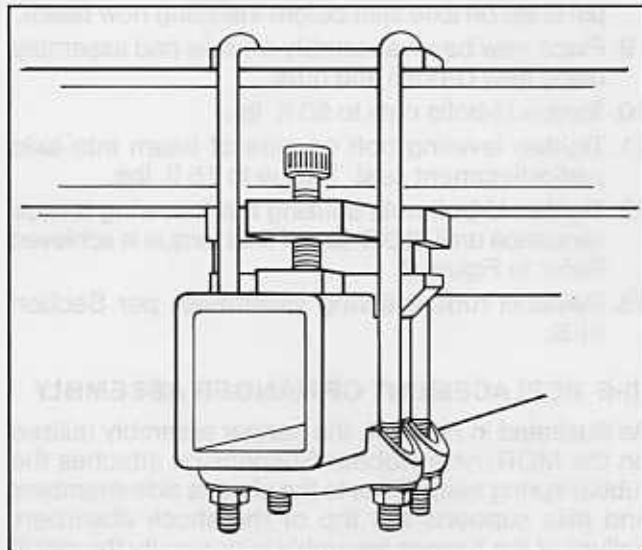

**Figure 10 — Beam Assembly Attachment to Axle Housing  
(Used Prior to October, 1986)**

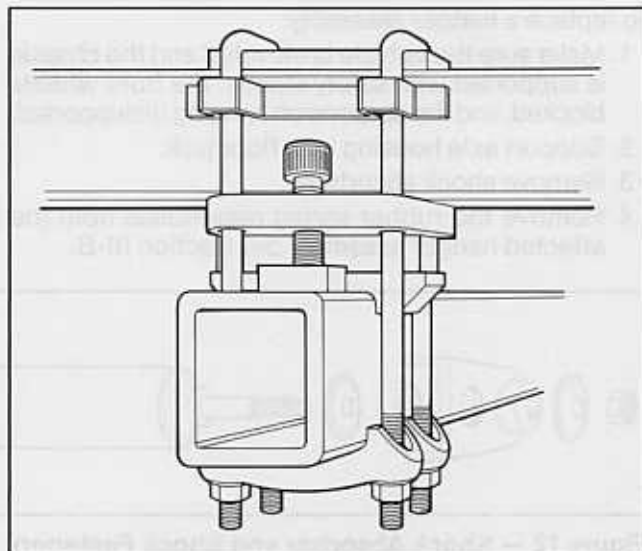

**Figure 11 — Beam Assembly Attachment to Axle Housing  
(Used October, 1986 to Present)**

To replace a beam assembly:

1. Make sure vehicle is elevated and chassis is supported with safety stands, the front wheels blocked, and the suspension hanging unsupported.
2. Remove tires and rims from the drive axle on side of vehicle to be repaired.
3. Support axle housing with floor jack.
4. Remove shock absorbers.

## SECTION III

5. Remove rubber spring assemblies from beam assembly per Section III-B.
6. Remove U-bolts.
7. Remove beam assembly from axle.
8. Make sure axle pad assembly with round or oblong pin is set on axle seat before installing new beam.
9. Place new beam assembly on axle pad assembly using new U-bolts and nuts.
10. Torque U-bolts nuts to 50 ft. lbs.
11. Tighten leveling bolt on side of beam into axle pad-adjustment seat. Torque to 75 ft. lbs.
12. Tighten U-bolt nuts utilizing the following torque sequence until 250 ft. lbs. of final torque is achieved. Refer to Figure 2.
13. Reinstall rubber spring assemblies per Section III-B.

### III-F. REPLACEMENT OF HANGER ASSEMBLY

As illustrated in Figure 4, the hanger assembly utilized on the MOR/ryde Rubber Suspension attaches the rubber spring assemblies to the chassis side-members and also supports the top of the shock absorbers. Failure of the hanger assembly is generally the result of the hanger assembly tie straps being loose or broken. (See Section III-C.)

To replace a hanger assembly:

1. Make sure the vehicle is elevated and the chassis is supported with safety stands, the front wheels blocked, and the suspension hanging unsupported.
2. Support axle housing with floor jack.
3. Remove shock absorbers.
4. Remove the rubber spring assemblies from the affected hanger assembly per Section III-B.

5. Remove cross-member straps attached to affected hanger assembly.
6. Remove hanger assembly from chassis side-member.
7. Before attaching new hanger assembly to chassis side-member, make sure the contact area is clean and free of any foreign material and metal shavings.
8. Install new hanger assembly on chassis side-member.
9. Reattach cross-member straps.
10. Torque all hanger assembly bolts first; then torque cross-member strap bolts per Torque Chart in Specification Section.
11. Reinstall rubber spring assemblies per Section III-B.
12. Reinstall shock absorber per Section III-G.

### III-G. REPLACEMENT OF SHOCK ABSORBER

The shock absorbers are made by Monroe with special valving specifically designed for the MOR/ryde Rubber Suspension. Refer to Figure 12. These shock absorbers are **not** available through any Monroe after-market dealers. Consult your Warehouse Distributor or MOR/ryde, Inc. for replacements.

To replace a shock absorber:

1. Remove fasteners.
2. Remove shock absorber.
3. Install new bushings on new shock absorber per exploded illustration below.
4. Install new shock absorber.
5. Torque fasteners per Torque Chart in Specification Section.

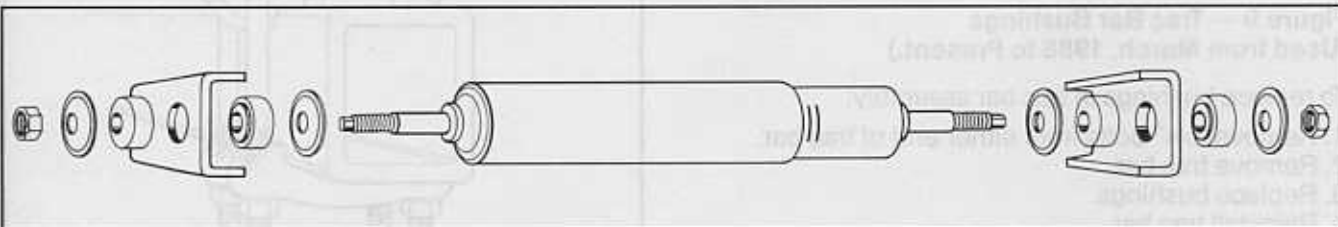

Figure 12 — Shock Absorber and Shock Fasteners

## SECTION IV

### SPECIFICATIONS

#### RUBBER SPRINGS

The springs in the MOR/ryde suspension are a special formulation of 100% natural rubber. The rubber springs are vulcanized (bonded) to steel plates.

MOR/ryde springs are shear-type springs which exhibit straight line load deflection characteristics. Through the use of different spring widths and different rubber compounds during the manufacturing process, many

## SECTION IV

different spring rate combinations are available. This provides the capability of fine tuning a vehicle for specific ride characteristics under predetermined load weights.

The widths of the MOR/ryde rubber springs are as follows:

Mor/ryde Part Number	Width
U0108-002	5.0"
U0108-003	6.50"
U0108-006	6.50"
U0108-010	5.0"

The MOR/ryde part number of the rubber spring is also permanently molded into the side of every rubber spring.

### TORQUE VALUES

USE THESE TORQUE VALUES UNLESS OTHERWISE SPECIFIED ON PRINT.

Bolt Size	Torque Ft. Lbs.	
	Grade 5	Grade 8
3/8"	24	35
7/16"	30	45
1/2"	45	69
5/8"	90	135
3/4"	150	222
7/8"	227	355

#### U-Bolts\*

5/8"	—	150
3/4"	150	225
7/8" /U-bolt not supplied by MOR/ryde	300	
7/8" /U-bolt supplied by MOR/ryde	525	

**Note: Torque values must be verified with a torque wrench. A calibrated pneumatic impact wrench is not an acceptable substitute.**

# M07 TRAC - BAR ADJUSTMENT

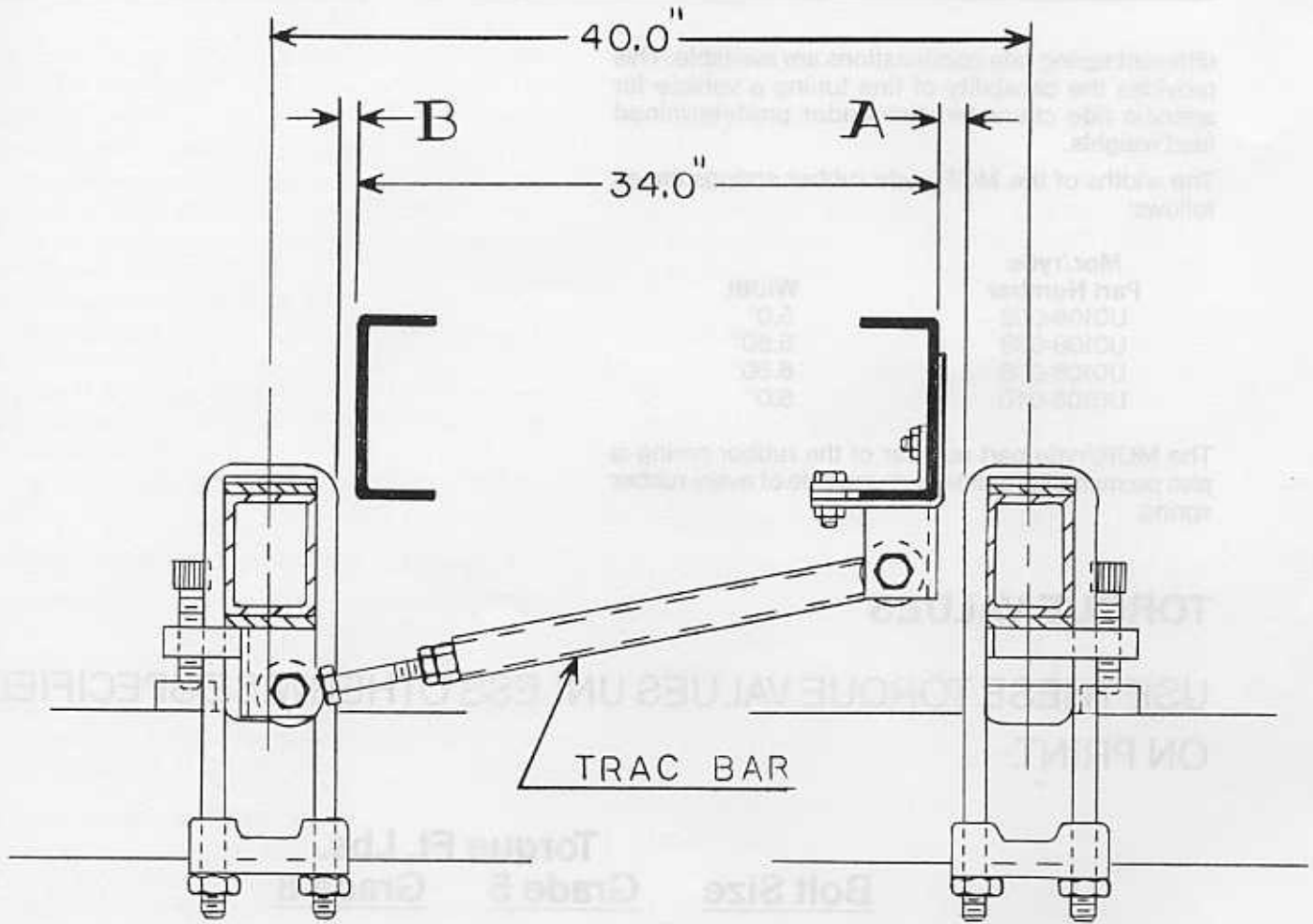

RUBBER  
SPRING  
DEFLECTION

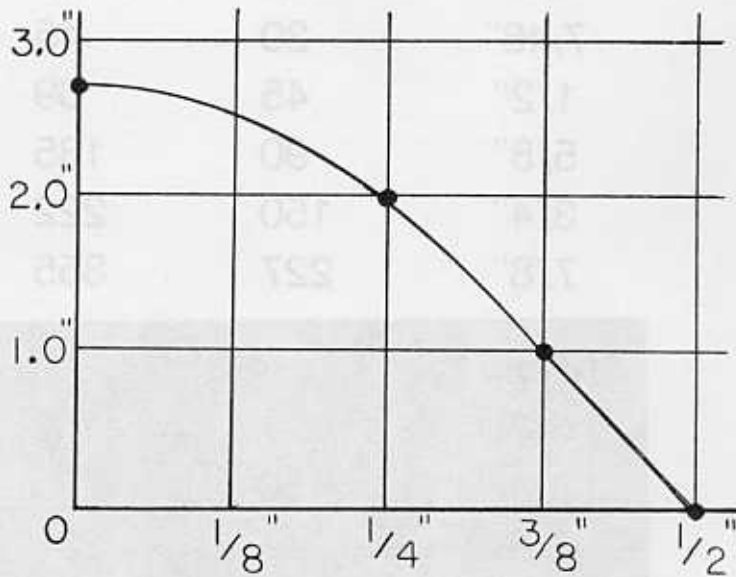

AMOUNT DIMENSION **A** IS GREATER THAN DIMENSION **B** WHEN ADJUSTING TRAC BAR.