

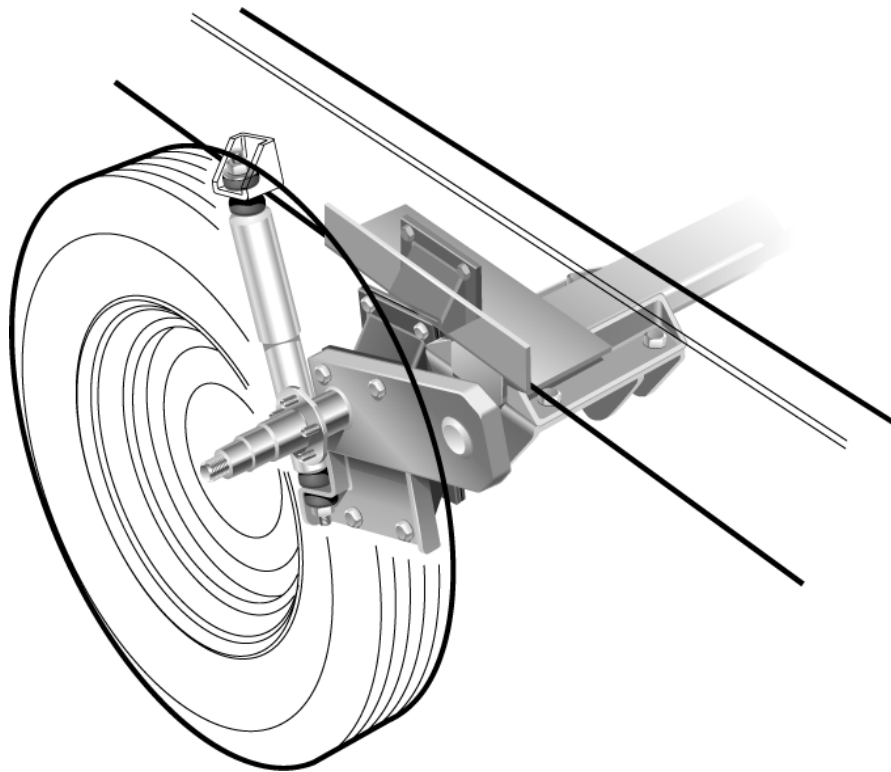

“IS”  
INDEPENDENT  
SUSPENSION SYSTEM  
OWNERS MANUAL



\* Made in U.S.A. Patent number 5899470

## **Description**

Congratulations on your purchase of the MOR/ryde “IS” suspension system\*. The MOR/ryde “IS” system has replaced your steel leaf springs and axle. With our “IS” independent design, we use rubber shear springs to isolate and absorb road shock and increase the dynamic wheel travel.

This provides you with:

- Much smoother towing
- Improved handling and towing
- Reduced vibration
- Better protection of the trailer from damaging road shock
- Height Adjustment

The MOR/ryde “IS” also features automotive style alignment features. This allows for toe and camber wheel alignment. Each “IS” system is designed specifically for the chassis of the trailer it is installed on. The “IS” system is available with a wide range of brake and bearing options.

Bearing Options:

- Standard 2 piece bearing units with inner & outer bearings
- E-Z lube bearings
- Never lube bearings by Dexter

Dexter Axle electric brake options:

- 12” X 2” rated at 7000 lb
- 12.25 x 2.5” rated at 7200 lb
- 12.25” x 3.38” rated at 8000 lb

Kodiak Hydraulic Disc Brake options:

- 7000 lb
- 8000 lb

For more information about the braking systems or bearing options on your trailer, please consult the owners manual provided by the brake/axle manufacturer.

## MOR/ryde “IS” Parts Listing

For ordering information please call (574) 293-1581 and ask for the parts department. The following diagram shows a breakdown of the parts in the “IS” suspension system. MOR/ryde also has replacement parts available for brakes, bearings, and hub and drum assemblies.

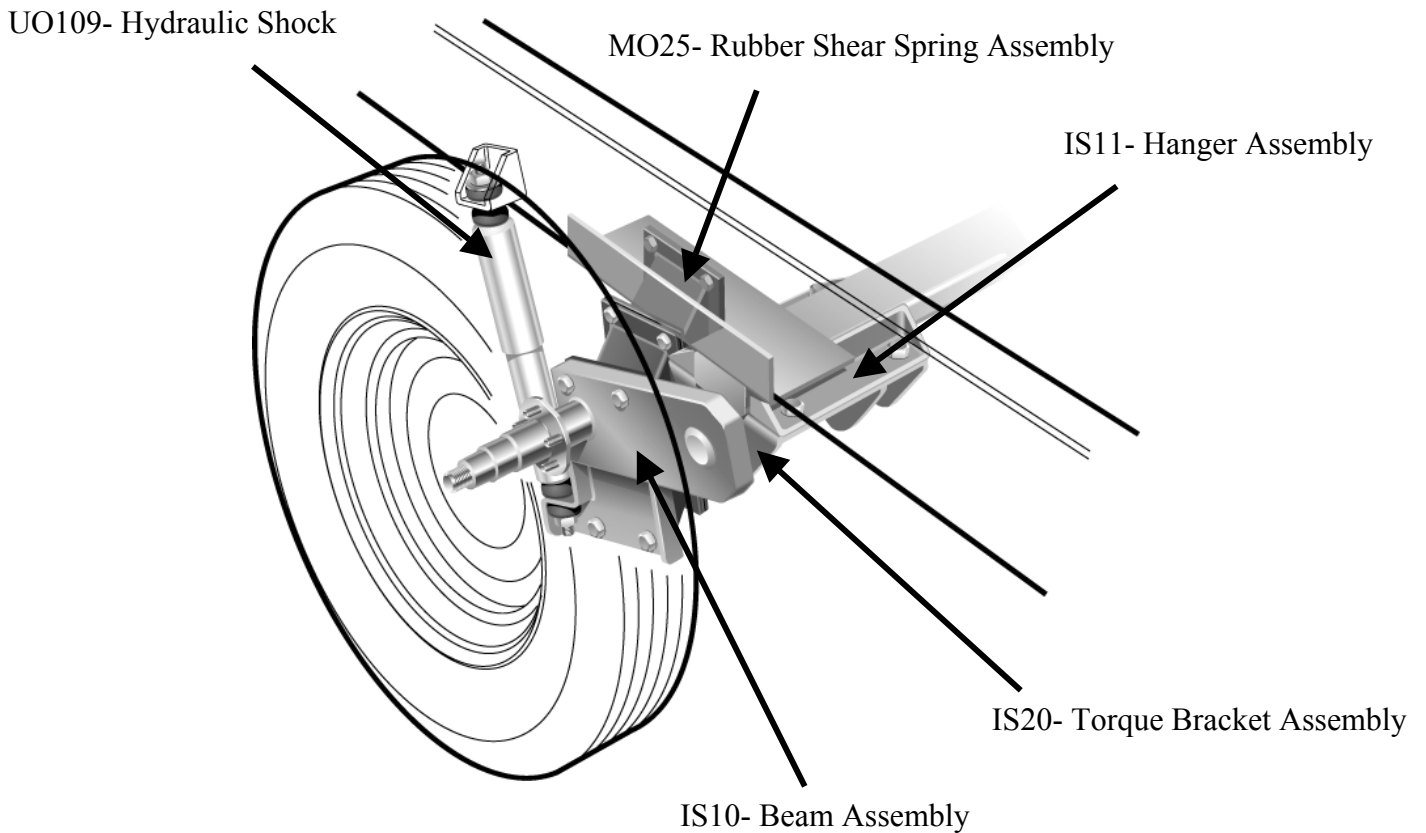

## TROUBLE SHOOTING / MAINTENANCE CHECKS

### Rubber Shear Spring Inspection

The rubber springs (Fig.1) should be periodically inspected for any tears or cracks. If a rubber spring has a 3” long and 3/4” deep crack or tear, the rubber should be replaced. Using a flat tool such as a putty knife can check this. The putty knife can be used to probe the rubber. If the knife can be inserted into the rubber to a depth of 3/4” or more and at a width of 3” or more the rubber should be replaced. *Note: It is normal to see rubber spring weather checking, which are small surface cracks in the rubber. Weather checking does not require a rubber spring to be replaced.*

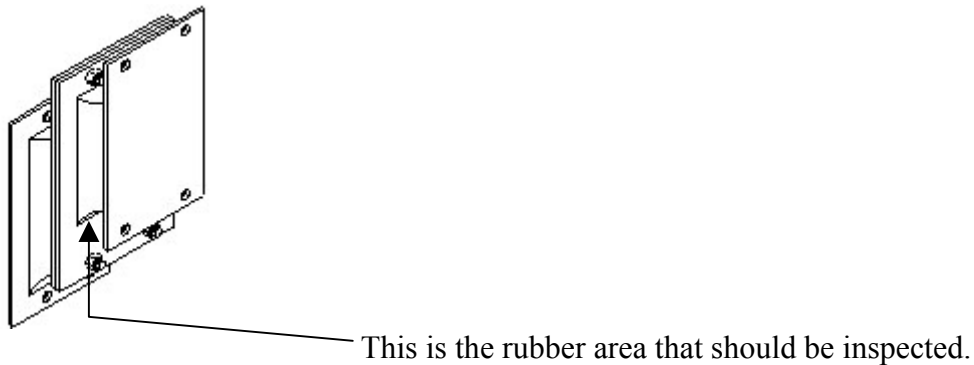
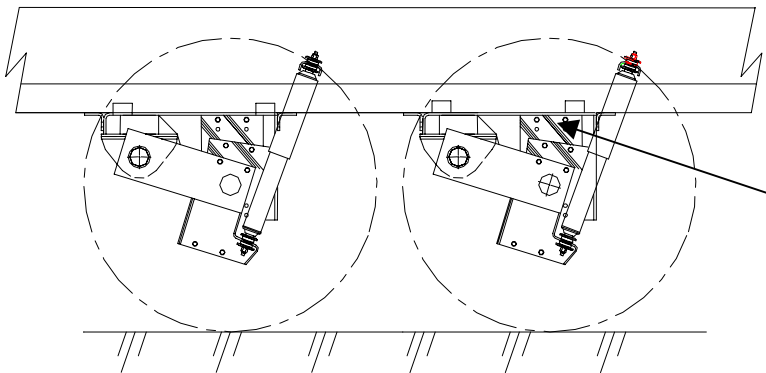

Fig. 1

### Height Adjustments

The MOR/ryde “IS” suspension system provides trailer height adjustment. There

← FRONT →



are extra sets of holes in the hanger assembly that can be used to adjust the height of the trailer. The trailer can also be adjusted from side to side to compensate for uneven loads. The adjustment holes are where the rubber springs bolt to the frame. Installing the rubber springs into the lower set of holes will raise the trailer 1”.

Fig. 2

## **Measuring Rubber Spring Deflection**

Park the vehicle on level ground. Measure dimension A, ground to bottom edge of the rubber spring at the hanger (fig. 3). Measure dimension B, ground to the bottom edge of the rubber spring at the spring carrier. Use the following formula to determine inches of rubber spring deflection:

Step 1: Dim. A – Dim. B = C

Step 2: Rubber Spring Deflection = 5-C

Nominal rubber spring deflection is 2-3 inches.

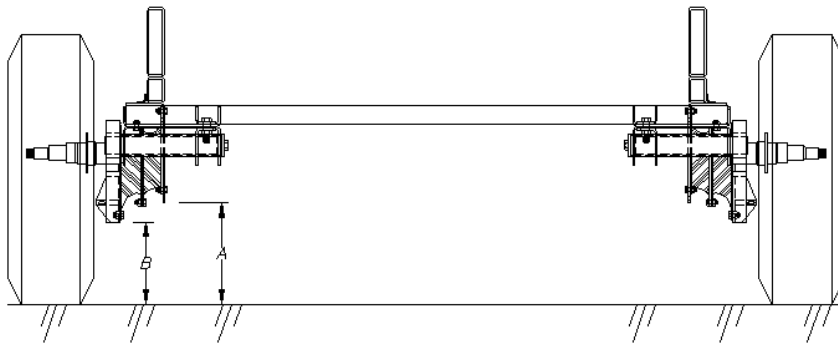

Fig. 3 (End View)

## **Alignment**

Wheel alignment should be done with equipment that is designed for multiple axle trailers. The MOR/ryde “IS” system is adjustable for both toe & camber. Any alignment shop capable of aligning full size trailers should be able to handle the job. The equipment used by MOR/ryde is a Hunter Laser Alignment model R611. Camber should be approx. +1/2 deg. to +1 deg. Toe should be approx. +/- .010” to +.060”.

## **Lubrication**

After November of 2001, the pivoting shaft will have a grease zerk on the under side of the torque bracket. It should be greased every 12 months or 6000 miles. For wheel bearing lubrication recommendations refer to the Axle service manual.

## **Shock Absorbers**

Monroe hydraulic shocks are standard equipment on all MOR/ryde “IS” style suspension systems. The shocks should be periodically inspected for oil leaks. If they are leaking or are broken, they should be replaced.

## **Basic Trouble Shooting**

Problem / symptom	Cause	Correction
Excessive tire wear	<p>Tires not aligned.</p> <p>Worn torque bracket bearings.</p> <p>Shock absorbers are worn.</p> <p>Improper tire pressure.</p>	<p>Have tires re-aligned</p> <p>Have the bearings replaced.</p> <p>Replace shock absorbers.</p> <p>Adjust air pressure.</p>
Rough ride	<p>Improper rubber spring deflection.</p> <p>Worn shock absorbers.</p> <p>Tires rubbing on wheel well or suspension system is bottoming out.</p>	<p>Call MOR/ryde service department to select a different rubber spring.</p> <p>Replace shock absorbers.</p> <p>Distance from the bottom of wheel well to top of tire is not adequate. If spring rubber spring deflection is correct, and height adjustment is not sufficient a spacer tube needs to be welded between the frame and the "IS" system.</p>
Excessive sway	<p>Improper tire pressure.</p> <p>Torn rubber spring.</p> <p>Improper hitch weight.</p>	<p>Adjust air pressure.</p> <p>Replace rubber spring.</p> <p>Travel Trailers should have 10%-12% hitch weight. 5<sup>th</sup> wheel trailers should have 20%-25% hitch weight.</p>

# MOR/ryde Rubber Suspension System

## LIMITED WARRANTY INDEPENDENT SUSPENSION

### Summary of Warranty

We, MOR/ryde, Inc., 1966 Moyer Avenue, P.O. Box 579, Elkhart, Indiana 46516 (“MOR/ryde”), warrant to you, the original first purchaser of new MOR/ryde rubber suspension system (“Product”), for a period of five (5) years from the date of original first purchase, or use or operation for a distance of fifty thousand (50,000) miles, whichever occurs first (“Warranty Period”), that the Product is free of defects in material or workmanship under normal use and service and will meet or exceed all of our advertised written specifications, excepting items and uses excluded from this Warranty. Labor charges are covered for 12 months from the original date of purchase.

### Examples of Items and Uses Excluded from Warranty

We are not responsible for, and this Warranty does not apply to, (a) any part of the Product that is defective or damaged due to abuse; misuse; neglect; accident; unauthorized replacement, repair, parts, or modification; (b) Products with no proof of mileage, or date of purchase; (c) duplication of repair due to faulty diagnosis or workmanship of others; (d) incorrect installation of any part of the Product, including but not limited to, incorrect torque on bolts; (e) loading the Product or any part of it beyond our rated load capacity; (f) towing expenses, freight charges, transportation expenses, telephone, telegraph or other communication expense, overtime or holiday labor, downtime or owner’s layover expenses such as meals and lodging; (g) re-springing suspension for ride adjustment; (h) failure of another component which results in our Product’s failure; (i) YOU ARE NOT ENTITLED TO RECOVER FROM US ANY CONSEQUENTIAL OR INCIDENTAL DAMAGES RESULTING FROM ANY DEFECT IN OUR PRODUCT. THIS INCLUDES ANY DAMAGE TO ANOTHER PRODUCT OR PRODUCTS RESULTING FROM SUCH A DEFECT. SOME STATES DO NOT ALLOW THE EXCLUSION OR LIMITATION OF INCIDENTAL OR CONSEQUENTIAL DAMAGES, SO THE ABOVE LIMITATION OR EXCLUSION MAY NOT APPLY TO YOU. EXCEPT AS OTHERWISE SPECIFICALLY DESCRIBED IN THIS WARRANTY, WE MAKE NO OTHER WARRANTY, EXPRESS OR IMPLIED, IN CONNECTION WITH OUR PRODUCT, INCLUDING ANY WARRANTY OF MERCHANTABILITY OR FITNESS FOR A PARTICULAR PURPOSE.

## What we will Do

We will remedy any defect in materials or workmanship by authorized repair or replacement. Warranty work can only be performed at our factory or authorized service centers. We will remedy the defect within a reasonable time after receipt of the defective Product at the factory or authorized service center. All our expenses in remedying the defect will be borne by us, including labor and material.

## How to Obtain Warranty Service

You must notify us of your need for warranty service not later than thirty (30) days after expiration of the Warranty Period. We will notify you of the nearest authorized service center to which you should deliver the Product. Corrective action will be taken within a reasonable time of the date of receipt of the defective Product by us at the factory, or at one of our authorized service centers. For further information about our factory or authorized service centers, write or call at the address or telephone number listed below.

## Alteration of this Warranty

NO PERSON HAS THE AUTHORITY TO ENLARGE, AMEND OR MODIFY THIS WARRANTY. THE WARRANTY IS NOT EXTENDED BY THE LENGTH OF TIME WHICH YOU ARE DEPRIVED OF THE USE OF THE PRODUCT. REPAIRS AND REPLACEMENT PARTS PROVIDED UNDER THE TERMS OF THIS WARRANTY SHALL CARRY ONLY THE UNEXPIRED PORTION OF THIS WARRANTY.

## Other Legal Rights

THIS WARRANTY GIVES YOU SPECIFIC LEGAL RIGHTS, AND YOU MAY ALSO HAVE OTHER RIGHTS WHICH VARY FROM STATE TO STATE. No action to enforce this Warranty shall be commenced later than ninety (90) days after expiration of the Warranty Period.

## Changes in Our Products

We reserve the right to change the design of any part of the Product, make additions or improvements to it from time to time, without notice and with no obligation to make corresponding changes or improvements to Products previously manufactured.

MOR/ryde, Inc.  
1966 Moyer Avenue  
P.O. Box 579  
Elkhart, Indiana 46516  
(574) 293-1581