

# XFactor

Performance Crossmembers by MOR/ryde

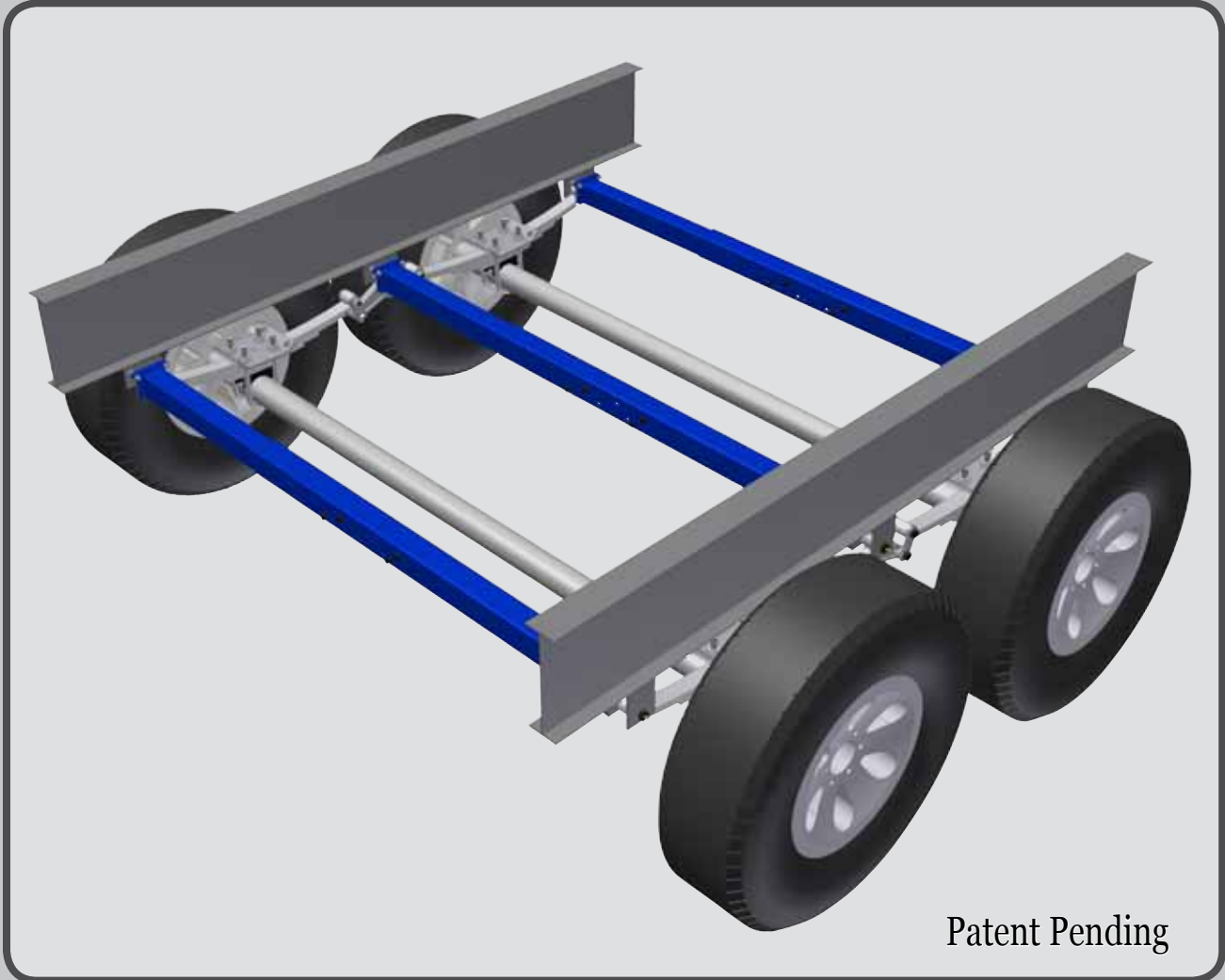

Patent Pending

**Xtra**  
Strong

**Xtra**  
Reinforcement



**Xtra**  
Peace of Mind

# TODAY'S ROADS ARE ROUGHER THAN EVER

Rough roads take a toll on even the best built vehicles. MOR/ryde has designed suspension systems for over 40 years to deal with rough roads. Now, they've taken that experience and designed a frame crossmember to help deal with the most extreme stresses your trailer frame will undergo.

The XFactor System is made of high strength steel in order to deal with even the most extreme frame stresses. Installation on the center spring hanger provides a significant reduction in frame stress from rough roads, tight cornering, and extreme side forces. For even more strength, the XFactor System can be installed at every hanger location.

# XFactor

Performance Crossmembers by MOR/ryde

**EASY INSTALLATION-  
NO WELDING  
NO DRILLING REQUIRED FOR  
STANDARD 3" WIDE SPRING HANGERS**

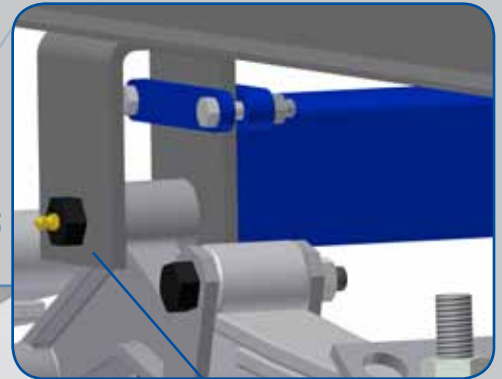

**GREASABLE  
ZERK BOLT  
INCLUDED!**

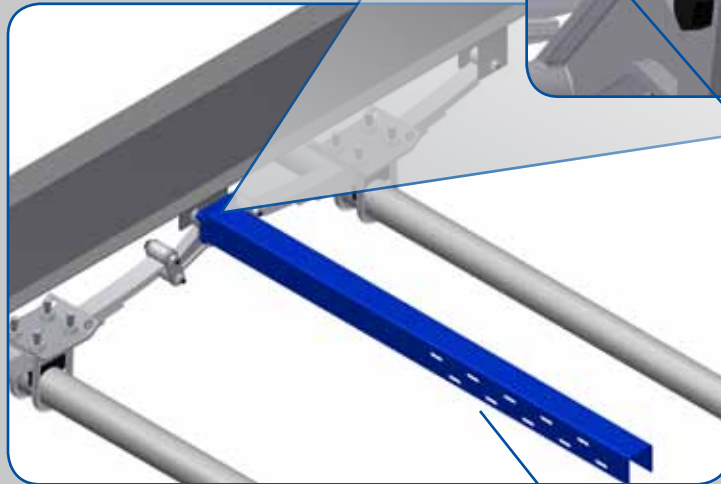

**FULLY ADJUSTABLE TO FIT  
DIFFERENT FRAMES**

## Xtra

Strong

**MADE OF HIGH STRENGTH LOW ALLOY STEEL**

## Xtra

Reinforcement

**AVAILABLE FOR 1, 2, 3 OR 4 POINT INSTALLATION FOR XTRA SECURITY**

## Xtra

Peace of Mind

**UP TO 94% REDUCTION IN FRAME STRESS AT EACH LOCATION**

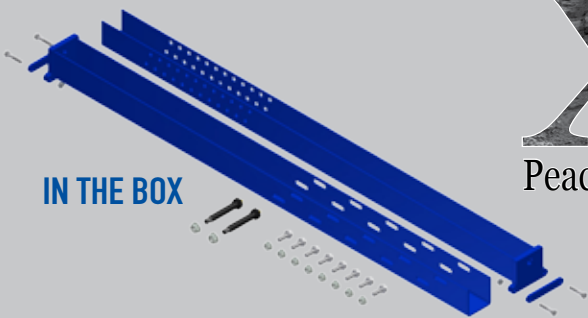

**IN THE BOX**

**MOR/RYPDE INTERNATIONAL, INC.  
1966 MOYER AVE., ELKHART, IN 46516  
(574) 293-1581 WWW.MORRYDE.COM**