

THE MOR/RYPDE® "IS" SUSPENSION SYSTEM

THE SUSPENSION SYSTEM THAT TOTALLY REDEFINES SMOOTH!

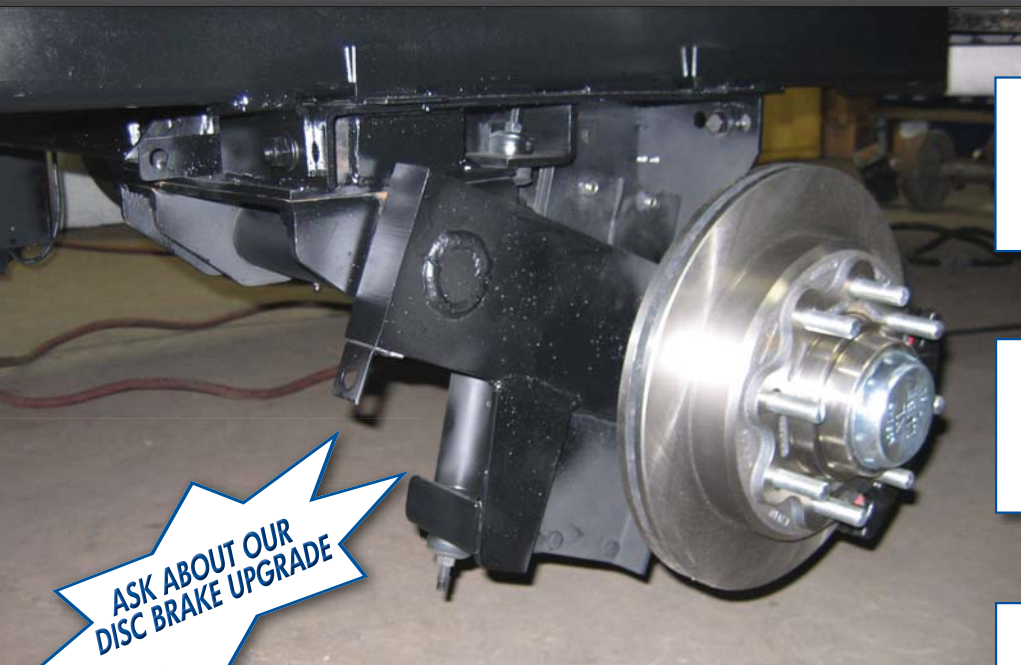

ASK ABOUT OUR
DISC BRAKE UPGRADE

The MOR/ryde Independent Suspension System (IS) is quite simply the best suspension system for 5th wheel and travel trailers on the market.

The "IS" system features:

- independent wheel action that allows each wheel to walk over bumps!
- double rubber shear springs that provide 5" of suspension travel as compared to 2" for steel leaf springs - providing maximum absorption of road shock and exceptional towing smoothness!
- specially valved shock absorbers - specifically valved to dampen road shock and control wheel hop!
- durable design with heavy duty components means no more broken leaf springs, hangers, or worn shackle plates!

**No MORE
BOUNCING & JOUNCING**

**No MORE
BROKEN LEAF SPRINGS**

**SUPERIOR
TOWING SMOOTHNESS**

**OUTSTANDING PROTECTION
FROM DAMAGING ROAD SHOCK**

1966 Moyer Avenue
P.O. Box 579
Elkhart, IN 46515-0579



Phone: 574.293.1581
Fax: 574.294.4936
www.morryde.com

THE MOR/RYPDE® "IS" SUSPENSION SYSTEM

DOUBLE RUBBER SPRING ASSEMBLY - significantly improves the suspension system's ability to absorb road shock and makes towing smoother. Result? MOR/ryde's suspension protects not only the trailer, but its components and contents as well - better than any other suspension system available today for towables.

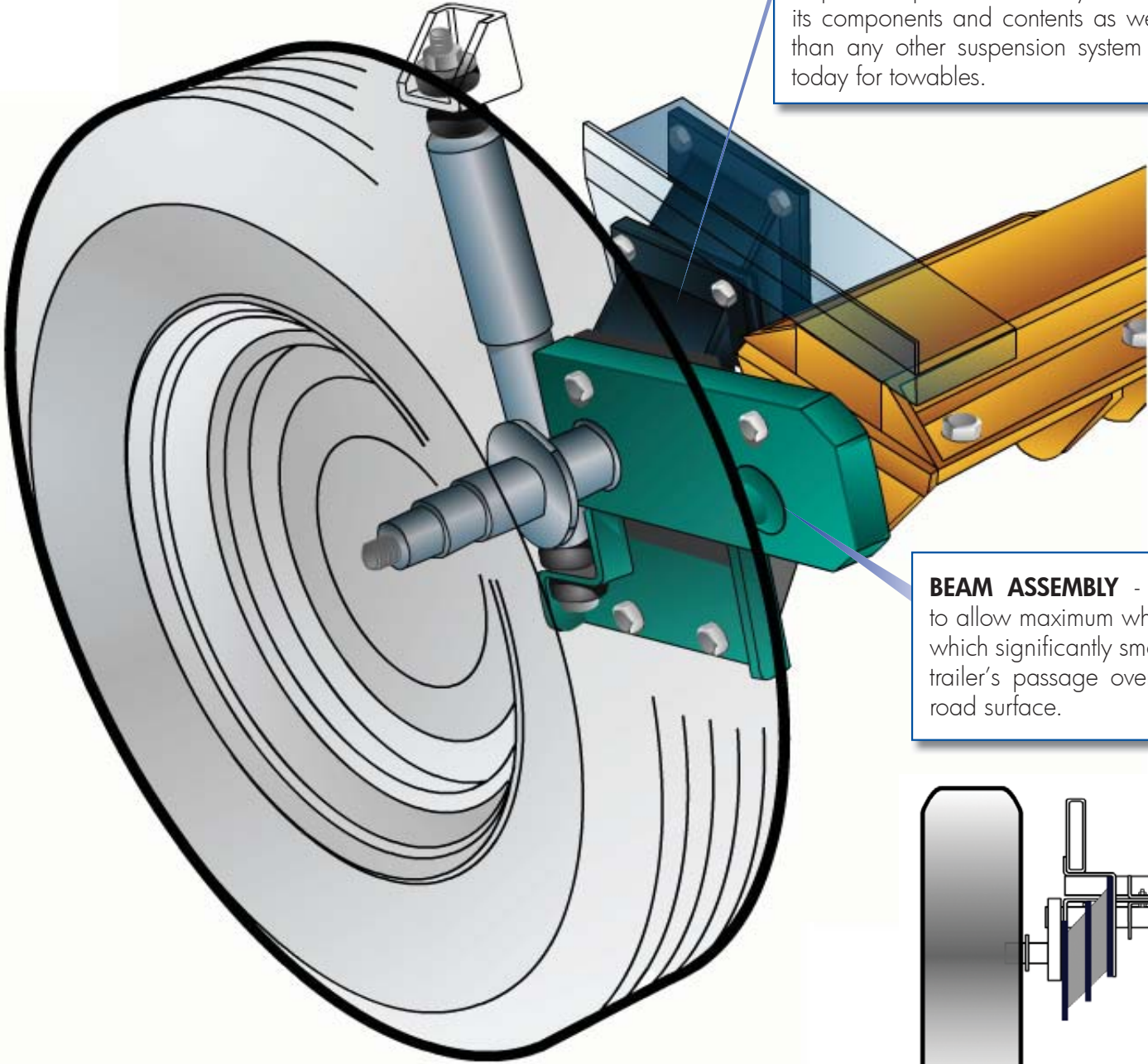

BEAM ASSEMBLY - designed to allow maximum wheel travel, which significantly smoothes the trailer's passage over a rough road surface.

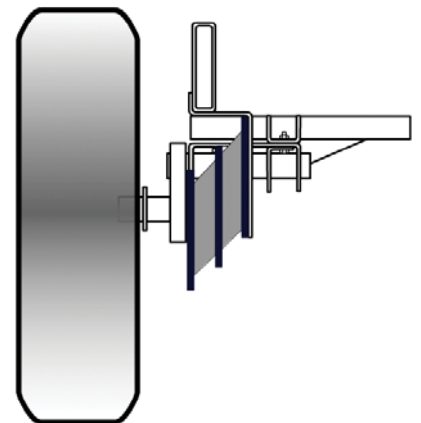

- *Superior towing smoothness*
- *Improved towability & handling*
- *Better protection of trailer, components & contents from damaging road shock*



SMOOTHING OUT THE ROUGH SPOTS.
www.morryde.com