

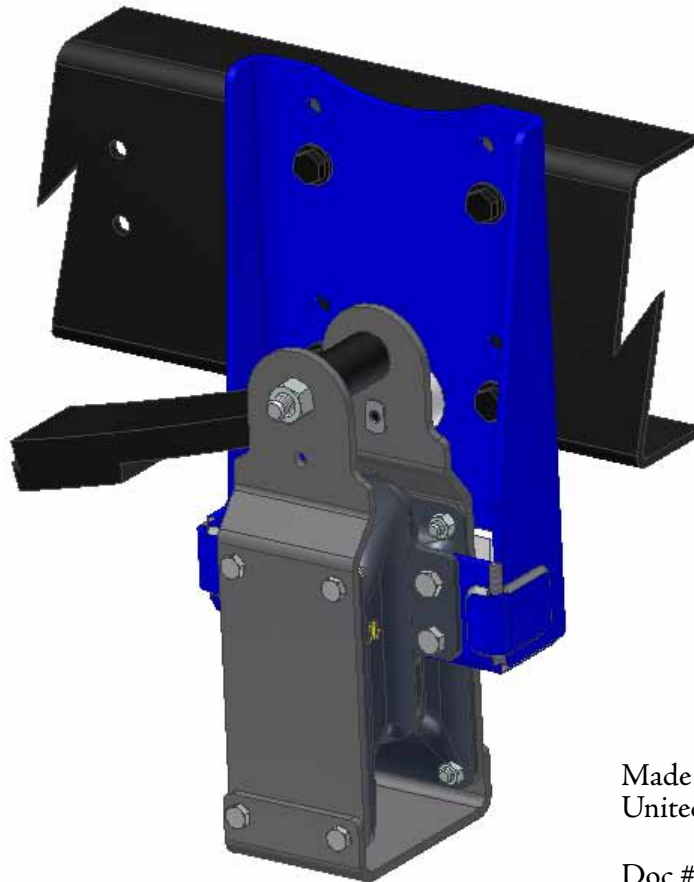

MOR/RYPDE DRIVE AXLE SUSPENSION SYSTEM
(DOUBLE EYE LEAF SPRING)

RS INSTALLATION INSTRUCTIONS

Instructions will assume procedures apply to both sides of the vehicle.



Made in the USA
United States Patent # 6,176,478

Doc # RS153-001

MOR/ryde "RS" Installation Instructions

Tools required:

- *Floor jacks
- *Safety stands
- Socket Set
- Hand Drill
- Cutting Torch
- Pneumatic Air Chisel
- Drift Pins
- Wrench Set
- Drill Bits
- Wheel Blocks

*Check for adequate capacity. It must support the weight of the rear of the vehicle.

The following may be required for exhaust modification:

- Reciprocating Saw
- Wire Welder

TYPICAL "RS" DRIVE AXLE SUSPENSION KIT

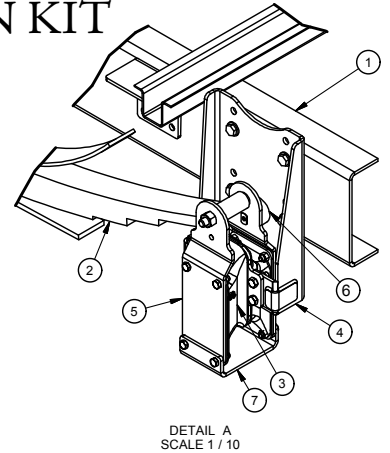
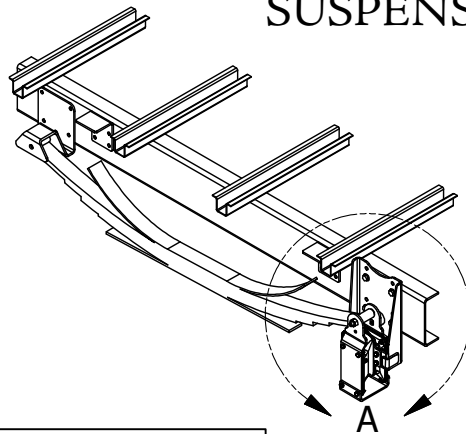

Torque Chart (ft-lbs+/-10%)		
Bolt Size	Grade 5	Grade 8
1/4-20	7	10
5/16-18	14	20
3/8-16	25	40
7/16-14	40	55
1/2-13	60	90
5/8-11	135	170
5/8-18	118	185
3/4-10	190	280

PARTS LIST	
ITEM	DESCRIPTION
1	CHASSIS FRAME
2	DOUBLE EYE LEAF SPRING
3	RUBBER SHEAR SPRING
4	FRAME HANGER (LH)
5	SPRING CARRIER
6	PLASTIC CONTROL PAD
7	JOUNCE BUMPER BRACKET



STEP 1 Be sure to block the front tires. Place floor jack under the differential and raise drive axle tires a minimum of 12" off the ground.



STEP 2 Place safety stands underneath the OEM frame and release the floor jack.

Be sure safety stands and floor jacks have sufficient capacity to safely support vehicle.



STEP 3 The exhaust pipe can not be closer than 1" from metal parts and no closer than 2" from rubber parts of the MOR/ryde system. If alteration of the exhaust is required, cut exhaust just behind the drive axle leaving 1 1/2" of straight flat pipe. Rejoin the exhaust at a later time. If no exhaust alteration is required go to STEP 4.



STEP 4 To facilitate installation one may want to remove the spare tire. Remove the rear spring eye shackle nut and bolt. If possible, raise the drive axle and remove the shackle nut and bolt over the top of the frame. If the spring hanger is above the leaf spring eye, lower the leaf spring to remove the spring eye bolt.

NOTE: Save spring eye nut and bolt for use later.



STEP 5 If the OEM spring hanger is riveted onto the frame, remove the rivets with an air chisel or a cutting torch (usually 4-8 rivets). If the hanger is bolted on, remove it with the appropriate tools.

DANGER: GASOLINE IS VERY FLAMMABLE. BE SURE THAT THE FUEL CELL, FUEL LINES, AND WIRE HARNESSSES ARE ADEQUATELY PROTECTED FROM SPARKS.



STEP 6 If the shackle was not removed in STEP 4, lower the spring eye below or raise above the frame and remove the spring eye bolt and nut.



STEP 7 With the appropriate drill bit, ream the existing spring hanger hole to be sure that the hole is clear of any debris. These holes will be used to bolt the MOR/ryde frame hanger to the OEM chassis.



STEP 8 The frame and leaf spring are now ready for installation of the MOR/ryde components.



STEP 9 Bolt the MOR/ryde frame hanger to the chassis through the existing holes that were reamed in STEP 7. If there are a double set of mounting holes in the frame hanger, using the set of holes closer to the top edge of the hanger will produce a taller ride height. Use the mounting hardware provided by MOR/ryde or reuse the existing hardware. A long handled socket wrench and mechanical fingers may be helpful. The nuts must be installed on the inside of the chassis frame. Tighten the bolts to the specified torque.



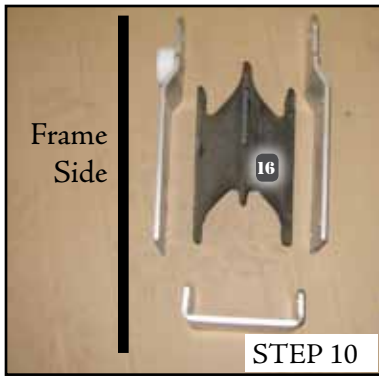

STEP 10 Note the orientation of the rubber shear spring assembly, spring carrier, spring carrier with plastic disk, and the jounce bumper bracket. The spring hanger with the plastic disk will be positioned against the frame hanger. Install the rubber spring so the side with identification number is attached to the spring carrier without the plastic disc.

Using (4) 3/8 x 1-16 bolts, assemble the spring carrier to the rubber spring. Assemble the jounce bumper bracket, spring carrier, and rubber spring using (4) 3/8 x 1 1/4-16 bolts. The nuts should be positioned against the rubber shear spring. Tighten the bolts to 40 ft lbs.



STEP 11 Use the floor jack to raise the axle until the rear spring eye is above the OEM frame rail. Using the spring eye bolt, install the spring carrier assembly onto the leaf spring. *The bolt head must face towards the OEM frame rail.

***NOTE:** On Ford E350 & E450 kits, use the new spring eye bolts and nuts provided.



STEP 12 Using a drift pin align the back bottom rubber spring mounting hole to the frame hanger mounting hole. Install the provided 7/16 x 1 1/4-14 bolt in the hole above the drift pin. Repeat this procedure on the opposite side. Raising the axle may help to align the remaining holes. Install the remaining rubber spring mounting bolts and torque to the appropriate specification. Torque the leaf spring eye bolt to 40 ft lbs.



STEP 13 Perform final check. Be sure all nuts and bolts are properly torqued. Refer to torque chart on Page 2. Verify the spring eye bolt is positioned with the bolt head toward the frame.

WARNING: The exhaust pipe must have a minimum of 2" of clearance to the MOR/ryde rubber shear spring and 1" to steel components. Premature rubber shear spring failure may occur if this clearance is not observed.